

AIR CURTAIN SERIES

Easi-Gard



Easi-Gard Air Curtain Series

The Invisible Wall

Working quietly, the Acson Easi-Gard Series acts as an invisible wall that contains the good and protects from the unwanted. The wide range of application enable it to be installed in numerous locations from over the doorways, windows and openings between indoor and outdoor or between two interior spaces.

Features

1 Centrifugal fan design with powerful airflow

2 Adjustable deflector to position according to different preferences

3 Quiet operation

4 Metal Casing for protection

5 Selectable fan speed with a switch control
• High & Low

6 Slim profile and elegant design blends with any interior

7 Simple installation in 3 simple steps:
fix installation plate, hand the body & tighten

8 Air flow up to 12ft height

The Good, Stays in

By minimizing leakage of cool, clean and desirable air, indoor temperature is kept without big fluctuations. This improves the occupants comfort level.

When cool air is kept in, compressor will be working less, hence lower energy consumption, power bill and longer lifetime, a definite winner against the rising cost. regulate the room's temperature.

The Bad, Stays out

Easi-gard series, act as an air-door to shield heat, airborne pollutants, oily mist, smoke and dust from getting into your good space. This improve the overall Indoor Air Quality (IAQ) by controlling at the source. due to bigger temperature fluctuation.

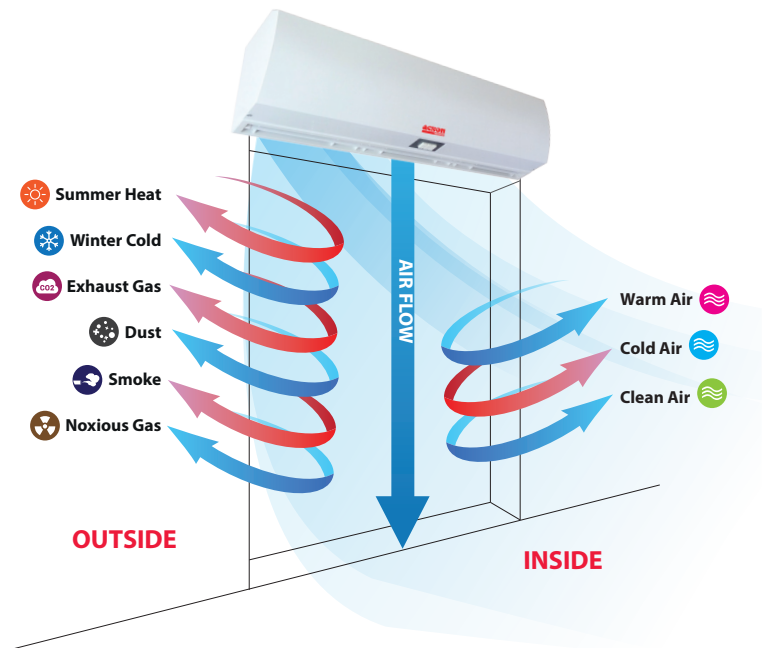

Places to install

Between Indoor and Outdoor

Café, Restaurants, Garage, Offices, Factory, Warehouse, Convention Center

Between Interior Spaces

Warehouse/Finish Good Area, Refrigeration Room, Kitchen, Air-Conditioned Space

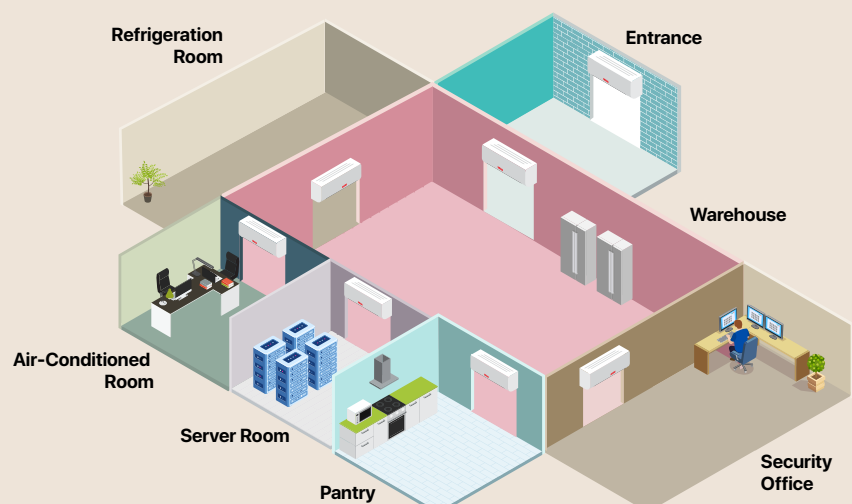

D STANDARD Series

Air Velocity Charts

ACA 308D & ACA 408D

ACA 310D & ACA 410D

ACA 312D & ACA 412D

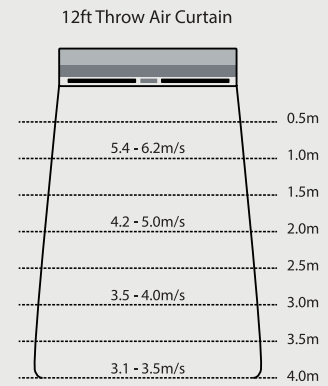
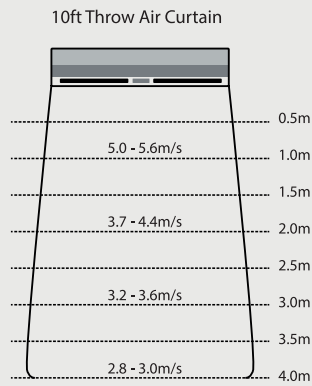
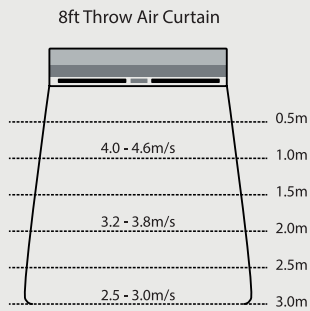

Installation Dimensions

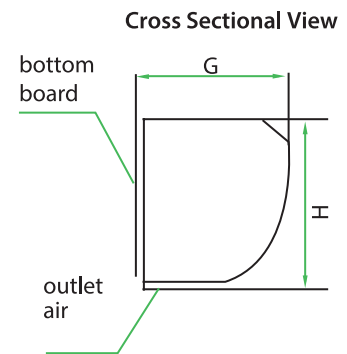
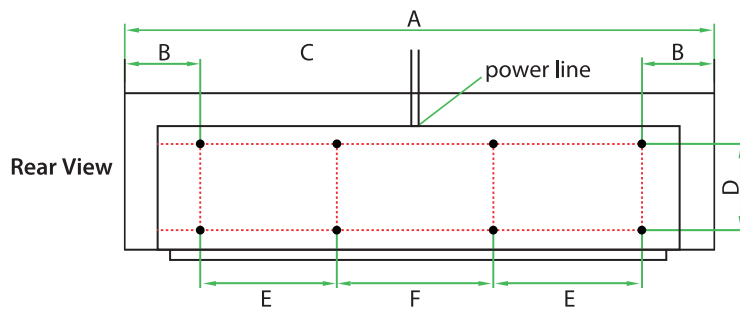

Model	Units Dimension (mm)							
	A	B	C	D	E	F	G	H
ACA 308D/310D/312D	900	105	345	120	230	230	212	230
ACA 408D/410D/412D	1200	105	495	120	330	330	212	230

Specifications

Model		ACA 308D		ACA 408D		ACA 310D		ACA 410D		ACA 312D		ACA 412D	
		HI	LOW	HI	LOW	HI	LOW	HI	LOW	HI	LOW	HI	LOW
Rated Voltage	V	220 - 240											
Rated Frequency	Hz	50											
Current	A	0.59	0.47	0.73	0.57	0.81	0.59	1.08	0.79	0.92	0.72	1.2	0.92
Input Power	W	130	104	160	127	195	142	260	189	218	171	285	222
Air Flow	CFM	580	482	754	620	635	510	810	700	698	600	1010	820
Air Speed	m/s	12.2	10.8	11.8	10.4	14.8	12.5	14.8	12.5	16.7	14.5	16.5	15.6
Sound Level	dB(A)	51	48	51	48	57	54	59	56	60	57	60	57
Unit Size (H x W x D)	mm	230 x 900 x 212		230 x 1200 x 212		230 x 900 x 212		230 x 1200 x 212		230 x 900 x 212		230 x 1200 x 212	
Net Weight	kg	17.0		21.0		17.0		21.0		17.0		21.0	

ACSON[®]
International
Air Conditioners

ACSON MALAYSIA SALES & SERVICE SDN.BHD.
a member of DAIKIN group

Business Registration NO.198401017130 (129688-D)

No. 7A, Jalan 13/4, Seksyen 13, 46200 Petaling Jaya,
Selangor Darul Ehsan, MALAYSIA.
Tel : +603 7964 8200 Sales Fax : +603 7956 9909
Service Fax : +603 7956 9907 Acson Careline : 1300 22 3344

Penang	: +604-5377 176	Pahang	: +609-5178 696
Perak	: +605-3129 828	Kelantan	: +609-7405 233
Melaka	: +606-2926 196	Sarawak	: +6082-344 128
Johor	: +607-3551 599	Sabah	: +6088-420 205

Authorized Dealer :

Products manufactured in an ISO certified facility.
This document contains the most current product information as of this printing.
For the most up-to-date product information, please logon to www.acson.com.my

CAT-ACA-2501

www.acson.com.my |     AcsonMalaysia