

CHILLED WATER SYSTEM

Hydro Technology



A5ACY-ER (AMAC-ER)
A5MAC-D/E
A5MAC-BR
Chilled Water Fan Coil Unit

ACSON
International
Air Conditioners



Acson Modular Chiller

Acson Modular Chiller is a versatile air-conditioning line-up that suit the most for commercial and industrial usage. It employs scroll compressors which are powerful and yet compact in size. It is the ideal choice for modern buildings as it can be integrated into the most diverse and inventive structures.

CHILLED WATER SYSTEM

Hydro Technology

Acson Chilled Water System could use air or water to cool down the refrigerant circuit. The cooled refrigerant is then circulated to a Brazed Plate Heat Exchanger (BPHE) where heat exchange will take place to cool down the water or glycol laced water. The chilled water is then circulated to the Fan Coil Unit (FCU) to cool desired place.

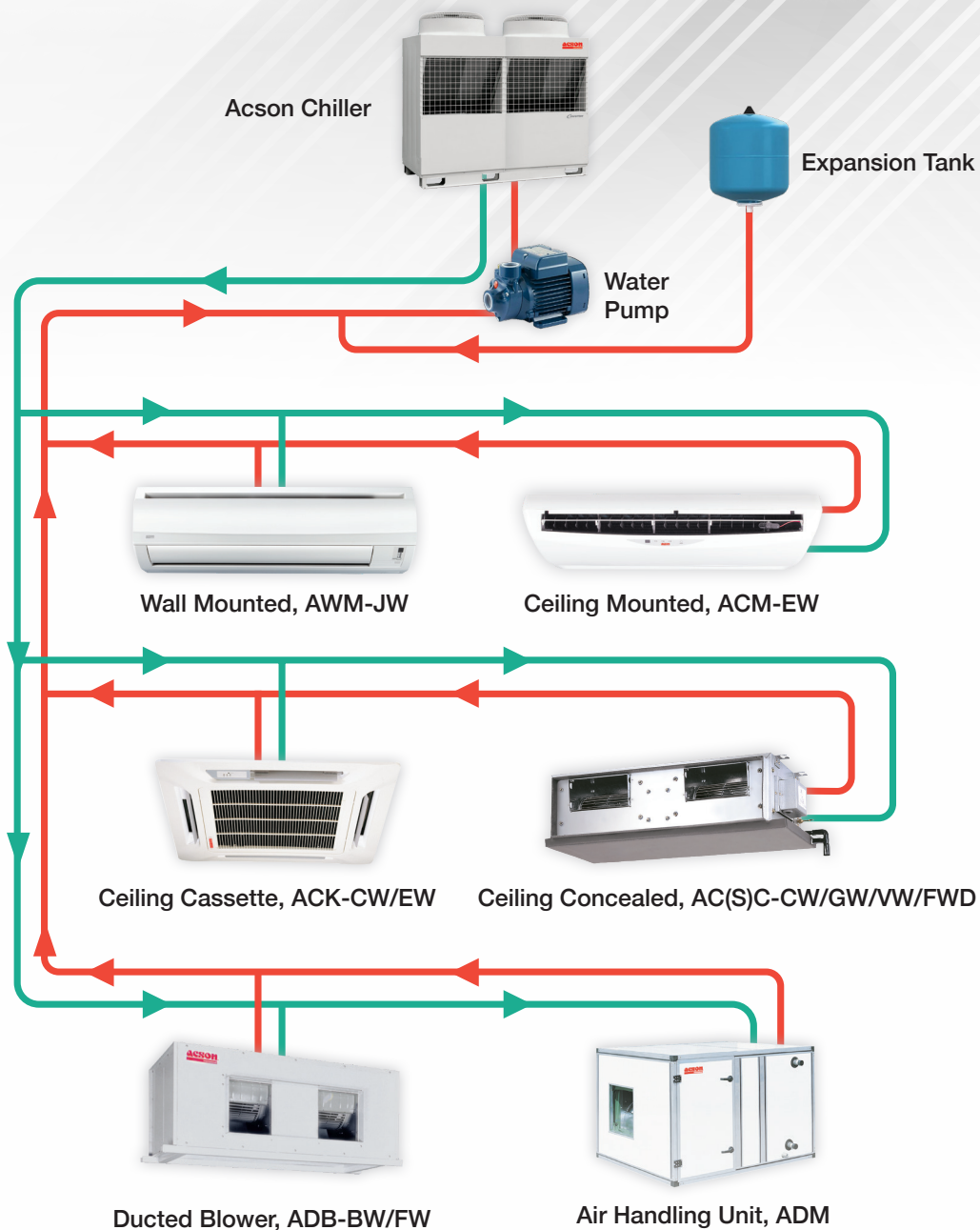

*Picture is for illustration purpose only.

Features

Long Piping Applications

Unlike normal Direct Expansion system with constraints in piping design and installation, Acson Chilled Water System allows for long piping application by correct pump sizing. All refrigerant circuit is within the system making it no risk of leakage in building and no oil return issue.

Partial Loading

Acson Chilled Water System is designed with two or more separate refrigerant circuits with multiple compressors. By doing so, the unit has part load capabilities. This will improve the reliability and energy efficiency especially during low loading operations.

* Mini Chiller - Applicable for A5ACY100-150ER

** Modular Chiller - Applicable for A5MAC210D~3360D, A5MAC230D~3680D, A5MAC230E~3680E, A5MAC340D~5440D, A5MAC450D~7200D, A5MWC20~320BR, A5MWC30BR~480BR & A5MWC40~640BR

Time and Cost Saving

As the unit is fully assembled in the factory and pass through a series of stringent quality control and assurance processes, mind is rest assured when installing the system. Refrigerant is also precharged to reduce the hustle of field charging and cost saving.

Brazed Plate Heat Exchanger

The heat exchanger is made of AISI 316 stainless steel plates closely arranged and brazed together to maximize heat exchange for higher efficiency.

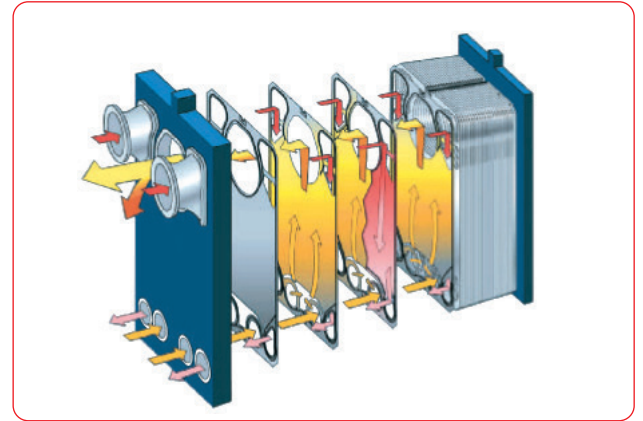

R410A



Environmental friendly R410A refrigerant system with zero Ozone Depletion Potential (ODP) is available upon request.

Compact Size

The Chilled Water System is so compact that it can be integrated perfectly with any architectural design, making it an ideal choice for house, office, restaurant and shop.

Air Cooled Modular Chilled Inverter E-Series (VRA)



Acson is committed to offer the new high efficiency inverter air-cooled modular chiller that meets the challenging need of today's market. With advanced technology, it combines both the benefits of R410A refrigerant and inverter in 1 united body. It is proper designed to provide the best coefficient of performance by option of using variable speed compressor instead of fixed-speed compressor to ensure the end product is compatible with various applications. Air-cooled Modular Chiller Inverter E Series is surely a people oriented solution for the next generation.

Model: A5MAC 230E
Cooling Capacity: 66 kW to 1056 kW
Refrigerant: R410A

Features

Inverter Technology



By advanced DC inverter technology, it provides the outstanding energy efficient performance. The module is equipped with a DC inverter compressor and fan motor, as well as intelligent inverter control system. The inverter driven feature multi speed driven compressors precisely match their output capacity according to load requirement, so that the module is always maintain at optimal energy efficiency operation.

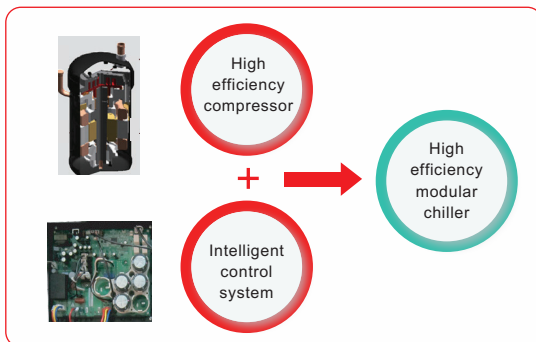

High Part Loading Efficiency

Acson inverter air cooled modular chiller (VRA) excel is part loading has IPLV value of 4.51.

Precise Temperature Control

The unique Inverter keeps room temperature stable by controlling the compressor at variable speed with minimum temperature fluctuation. Thus, each unit auto adaptive to real capacity needs for a high level of comfort.

Precise & Stable Temperature Control

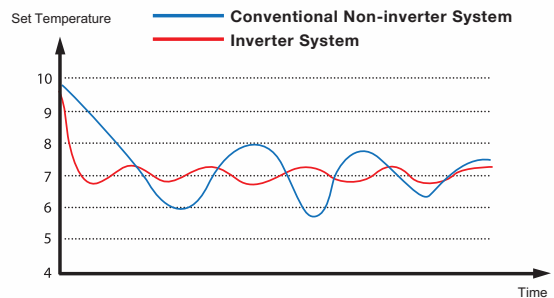

Inverter	Non-Inverter
<ul style="list-style-type: none"> Compressor speed changes Compressor slow down when reaches set temperature 	<ul style="list-style-type: none"> Compressor single speed Temperature falls/rises significantly.

Rapid Cooling

Able to optimize in shorter period of time.

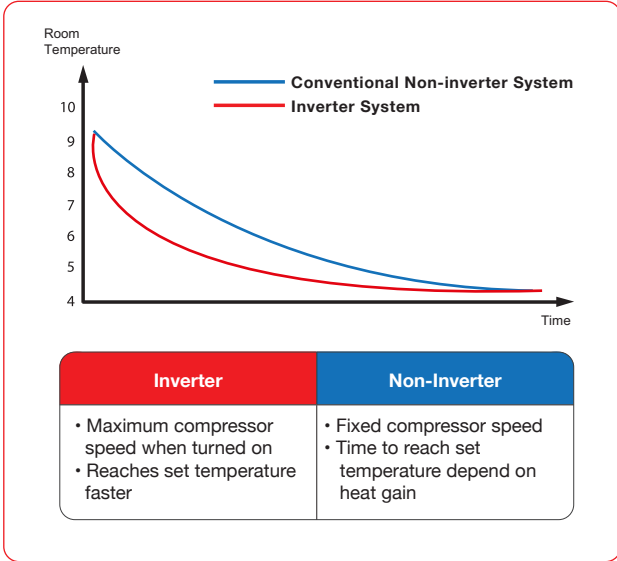

Low Inrush Current

Inverter driven compressor requires lower starting torque which features soft start to ensure a smooth ramp up profile without withdrawing high current. This aspect avoid peak fluctuation that potential to harm sensitive equipment and no need of expensive additional components for power factor correction.

Expandable Capacity

The beauty of modular design feature new levels of unit compact in size and configuration which facilitates flexibility in expands of capacity for building extension by arbitrary combination up to 16 units to cater to additional cooling requirements.

Redundant Operation

Redundancy feature back up capacity and capabilities to continue to run given a component failure. Fault of any unit can be isolated for service and will not affect the normal operation of other units.

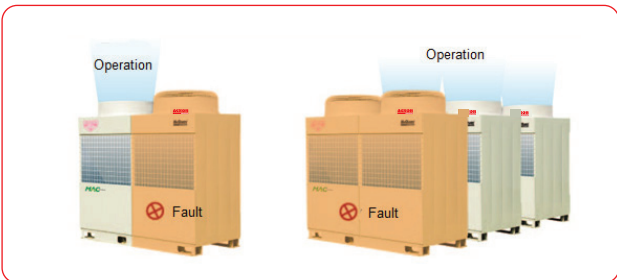

Diverse System Solution

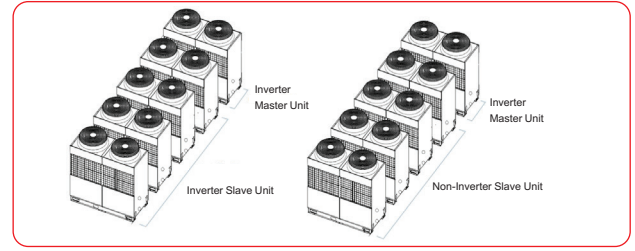

*Maximum number of a system is 16 units.
*Non - inverter is D model ranges from A5MAC210, 230, 340 and 450D depends on model.

Relative Humidity Control

Control of temperature and relative humidity can be achieved precisely by adding accessories such as heating coil and electrical heater.

Supply Fresh Air Regulation

Able to couple with different Air Handling Unit (AHU) which fresh air can be easily introduce from outside and extract stale air to the outside thus improve Indoor Air Quality (IAQ).

Practically Silent Operation

The inverter sound performance introduces sound level as low as 58dBA with respect to conventional unit. At part-load conditions, typical at the night, the inverter device adjust speed variation to have lower sound levels than conventional on-off compressor systems in both running and start-up periods.

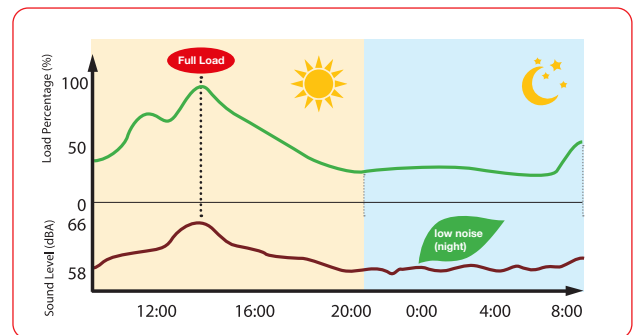

Ez-Comm for ModBus Communication

Acson Inverter Air Cooled Modular Chiller has a standard Modbus port that can be easily connect to Building Automation System (BAS). Making centralized control can be easily achieve.

Specifications

A5MAC 230E - A5MAC 1380E (R410A)

Model			A5MAC 230E	A5MAC 460E	A5MAC 690E	A5MAC 920E	A5MAC 1150E	A5MAC 1380E	
Nominal cooling capacity	BTU/h		221,790	443,580	665,370	887,160	1,108,950	1,330,740	
	kW		65	130	195	260	325	390	
Nominal Total Input Power	kW		21.80	43.60	65.40	87.20	109.00	130.80	
Nominal Running current	A		35.90	71.80	107.70	143.60	179.50	215.40	
EER	BTU/h/W		10.17						
COP	W/W		2.98						
IPLV			4.51						
Power Source	V/Ph/Hz		380 ~ 415/3/50						
Refrigerant Control			EXV						
Sound Level Pressure	dBA		67.5	70.51	72.27	73.52	74.89	75.28	
Nominal Water Flow Rate	m ³ /h		11.2	22.4	33.6	44.8	56	67.2	
Nominal Water Pressure Drop	kPa		55	110	165	220	275	330	
Pipe	Size	mm (in)	50.8 (2)						
Unit Dimension	Height	mm (in)	1,840 (72)						
	Width	mm (in)	1,990 (78)						
	Depth	mm (in)	840 (33)	2,080 (82)	3,320 (131)	4,560 (180)	5,800 (228)	7,040 (277)	
Packing Dimension (Individual)	Height	mm (in)	2,010 (79)						
	Width	mm (in)	2,010 (79)						
	Depth	mm (in)	890 (35)						
Net Weight	kg (lb)		491 (1,082)	982 (2,165)	1,473 (3,247)	1,964 (4,330)	2,455 (5,390)	2946 (6495)	
Gross Weight	kg (lb)		531 (1,171)	1,062 (2,341)	1,593 (3,512)	2,124 (4,683)	2,655 (5,853)	3,186 (7,024)	
Operating Weight	kg (lb)		500 (1,102)	1,000 (2,205)	1,500 (3,307)	2,000 (4,409)	2,500 (5,512)	3,000 (6,614)	
Refrigerant	Type		R410A						
	Charge	kg (lb)	19.4 (42.8)	38.8 (85.5)	58.2 (128.3)	77.6 (171.1)	97 (213.8)	116.4 (256.6)	

Arbitrary combination up to 16 modules

Notes:

- Unit dimension is taken assuming units is stacked front facing the back and with installation clearance.
- Nominal cooling capacity are based on the conditions below:

Mode		Cooling
Evaporator	Leaving Water Temperature	7°C
Condenser	Ambient Temperature	35°C DB / 24° C WB
Nominal Flow Rate		0.172 m ³ /h.kW

- IPLV = COP of 100% LOAD @ 35C AMBIENT x 2.3% + COP of 75% LOAD @ 31.5C AMBIENT x 41.5% + COP in 50% LOAD @ 28.0C AMBIENT x 46.1% + COP IN 25% LOAD @ 24.5C AMBIENT x 10.1.
- Parameter above is tested under rated voltage of 380V.
- Water pressure drop includes water pressure drop of both the unit and the strainer.
- For maximum running current ambient temperature is 43C.
- Combination above is in series, parameter such as water flowrate vary depend on design.
- All specifications are subjected to change by the manufacturer without prior notice.

Air Cooled Modular Chiller D Series

Model							
		A5MAC 210D-3360D	A5MAC 230D-3680D	A5MAC 340D-5440D	A5MAC 450D-7200D	A5MAC1000D-16000D	
Cooling Capacity	kW	60 - 960	65 - 1040	100 - 1600	135 - 2160	295 - 4720	
Refrigerant		R410A					

Features

Modular Design

The modular chiller allows for combination of up to 16 base modules unit for D series where each module can be connected to form a much larger system.

Base Module	A5MAC 210D	A5MAC 230D	A5MAC 340D	A5MAC 450D	A5MAC 1000D
Modular Chiller D Series	A5MAC 420D	A5MAC 460D	A5MAC 680D	A5MAC 900D	A5MAC 2000D
	A5MAC 630D	A5MAC 690D	A5MAC 1020D	A5MAC 1350D	A5MAC 3000D
	A5MAC 840D	A5MAC 920D	A5MAC 1360D	A5MAC 1800D	A5MAC 4000D
	A5MAC 1050D	A5MAC 1150D	A5MAC 1700D	A5MAC 2250D	A5MAC 5000D
	A5MAC 1260D	A5MAC 1380D	A5MAC 2040D	A5MAC 2700D	A5MAC 6000D

Intelligent Control System with Safety Protection

An user friendly intelligent control system is built into the modular chiller. Microchip and large-scaled LCD display are employed to make the control swift and easy. The modular chiller is equipped with a series of safety control including the high/low pressure switch to ensure safe operation .

	AMAC 210D	AMAC 230D	AMAC 340D	AMAC 450D	AMAC 1000D
Intelligent Control System	Port provided for BMS		Built in Modbus		

Ez-Comm for ModBus Communication

The Ez-Comm is a data converter that coordinates Acson modular chiller unit control system and controls inter-system communications based on the ModBus communication protocol. It automatically converts the internal communication protocol of Acson modular chiller unit into the ModBus communication protocol to ensure that the unit is connected to the BAS system that is based on the ModBus RTU communication protocol and uses the RS485 communication mode.

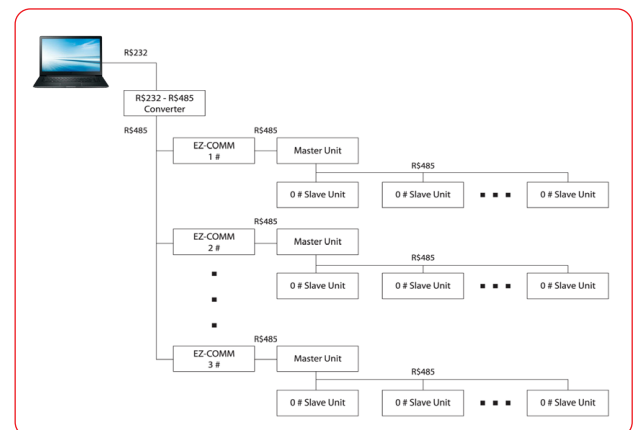

Note:
 A5MAC 340D, A5MAC 450D & A5MAC 1000D ModBus is built-in.
 A5MAC 210D & A5MAC 230D is optional.
 Please consult us for more details.

Low Noise Operation

The specially designed spiral blades ensure smooth air flow, significantly reducing the turbulence and lowering sound level.

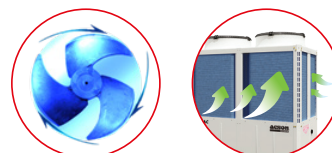

Specifications

A5MAC 210D - A5MAC 1260D (R410A)

Model		A5MAC 210D	A5MAC 420D	A5MAC 630D	A5MAC 840D	A5MAC 1050D	A5MAC 1260D
Nominal Cooling Capacity	BTU/h	205,000	410,000	615,000	820,000	1,025,000	1,230,000
	kW	60.00	120.00	180.00	240.00	300.00	360.00
Nominal Total Input Power	kW	18.80	37.60	56.40	75.20	94.00	112.80
Nominal Running Current	A	36.00	72.00	108.00	144.00	180.00	216.00
EER	BTU/h/W	10.90					
COP	W/W	3.19					
Power Source	V/Ph/Hz	380~415 / 3 / 50					
Refrigerant Control		EXV					
Sound Pressure Level	dBa	66	69	71	72	73	74
Nominal Water Flow Rate	m ³ /h	10.3	20.6	30.9	41.2	51.5	61.8
Nominal Water Pressure Drop Per Unit	kPa	38					
Pipe	Size	mm(in)					
Unit Dimension	Height	mm(in)					
	Width	mm(in)					
	Depth	840 (33)	2,080 (82)	3,320 (131)	4,560 (180)	5,800 (228)	7,040 (277)
Packing Dimension (Individual)	Height	mm(in)					
	Width	mm(in)					
	Depth	mm(in)					
Net Weight	kg/lb	520 (1,146)	1,040 (2,293)	1,560 (3,439)	2,080 (4,586)	2,600 (5,732)	3,120(6,878)
Gross Weight	kg/lb	570 (1,257)	1,140 (2,513)	1,710 (3,770)	2,280 (5,027)	2,850 (6,283)	3,420 (7,540)
Refrigerant	Type	R410A					
	Charge	kg/lb	11.6 (26)	23.2 (51)	34.8 (77)	46.4 (102)	58 (128)

Arbitrary combination up to 16 modules

Notes:

- Unit dimension is taken assuming units is stacked front facing the back and with installation clearance
- Nominal cooling capacity are based on the conditions below:

Mode		Cooling
Evaporator	Leaving Water Temperature	7°C
Condenser	Ambient Temperature	35°C DB / 24° C WB
Nominal Flow Rate		0.172 m ³ /h.kW

- Nominal water flow rate and pressure drop is based on series installation method.
- All specifications are subjected to change by the manufacturer without prior notice.

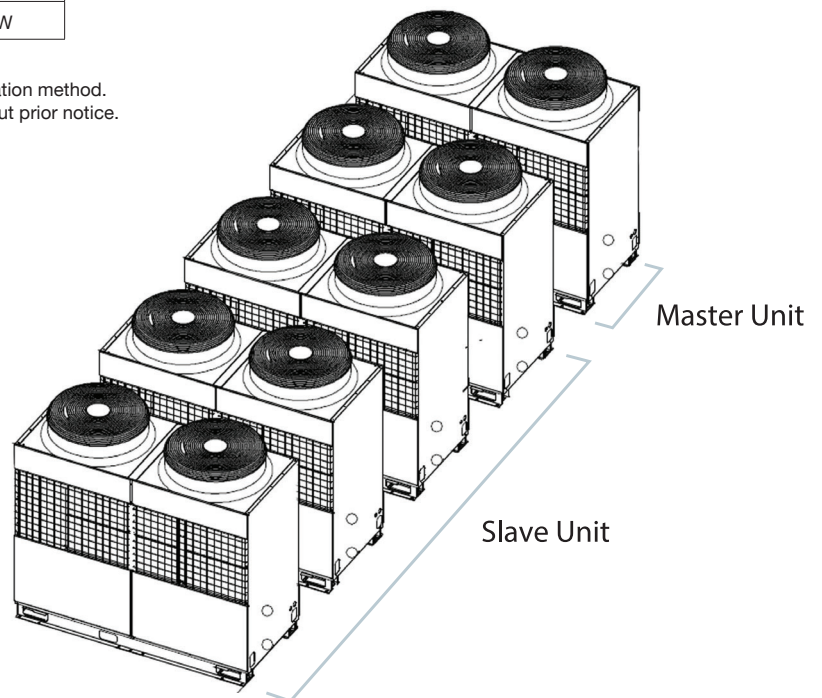

Specifications

A5MAC 230D - A5MAC 1380D (R410A)

Model			A5MAC 230D	A5MAC 460D	A5MAC 690D	A5MAC 920D	A5MAC 1150D	A5MAC 1380D
Nominal Cooling Capacity	BTU/h		225,300	450,500	675,700	900,900	1,126,100	1,351,300
	kW		66	132	198	264	330	396
Nominal Total Input Power	kW		20.3	40.6	60.9	81.2	101.5	121.8
Nominal Running Current	A		38.1	76.2	114.3	152.4	190.5	228.6
EER	BTU/h/W		11.10					
COP	W/W		3.25					
Power Source	V/Ph/Hz		380 ~ 415 / 3 / 50					
Refrigerant Control			EXV					
Sound Pressure Level	dBA		66	69	71	72	73	74
Nominal Water Flow Rate	m³/h		11.3	22.6	33.9	45.2	56.5	67.8
Nominal Water Pressure Drop Per Unit	kPa		55					
Pipe	Size	mm (in)	50.8 (2)					
Unit Dimension	Height	mm (in)	1,840 (72)					
	Width	mm (in)	1,990 (78)					
	Depth	mm (in)	840 (33)	2,080 (82)	3,320 (131)	4,560 (180)	5,800 (228)	7,040 (277)
Packing Dimension (Individual)	Height	mm (in)	2,010 (79)					
	Width	mm (in)	2,010 (79)					
	Depth	mm (in)	890 (35)					
Net Weight	kg (lb)		471 (1,038)	942 (2,077)	1413 (3,115)	1884 (4,154)	2355 (5,192)	2826 (6,230)
Gross Weight	kg (lb)		511 (1,127)	1022 (2,253)	1533 (3,380)	2044 (4,506)	2555 (5,633)	3066 (6,759)
Operating Weight	kg (lb)		480 (1,058)	960 (2,116)	1440 (3,175)	1920 (4,233)	2400 (5,291)	2880 (6,349)
Refrigerant	Type		R410A					
	Charge	kg (lb)	17.0 (38)	34 (75)	51 (112)	68 (150)	85 (187)	102 (225)

Arbitrary combination up to 16 modules

Notes:

- Unit dimension is taken assuming units is stacked front facing the back and with installation clearance
- Nominal cooling capacity are based on the conditions below:

Mode		Cooling
Evaporator	Leaving Water Temperature	7°C
Condenser	Ambient Temperature	35°C DB / 24° C WB
Nominal Flow Rate		0.172 m³/h.kW

- Nominal water flow rate and pressure drop is based on series installation method.
- All specifications are subjected to change by the manufacturer without prior notice.



Specifications

A5MAC 340D - A5MAC 2040D (R410A)

Model		A5MAC 340D	A5MAC 680D	A5MAC 1020D	A5MAC 1360D	A5MAC 1700D	A5MAC 2040D
Nominal Cooling Capacity	BTU/h	341,300	682,500	1,023,700	1,364,900	1,706,100	2,047,300
	kW	100	200	300	400	500	600
Nominal Total Input Power	kW	30.5	61.0	91.5	122.0	152.5	183.0
Nominal Running Current	A	54.4	108.8	163.2	217.6	272.0	326.4
EER	BTU/h/W	11.20					
COP	W/W	3.28					
Power Source	V/Ph/Hz	380~415 / 3 / 50					
Refrigerant Control		EXV					
Sound Pressure Level	dBA	67	70	71.8	73	74	74.8
Nominal Water Flow Rate	m³/h	17.2	34.4	51.6	68.8	86	103.2
Nominal Water Pressure Drop Per Unit	kPa	28					
Pipe	Type	RC (INTERNAL TAPPER)					
	Size	63.5 (2 - 1/2)					
Unit Dimension	Height	2,300 (90)					
	Width	2,100 (83)					
	Depth	1,100 (43)	2,744 (108)	4,388 (173)	6,032 (237)	7,676 (302)	9,320 (367)
Packing Dimension (Individual)	Height	2,430 (96)					
	Width	2,175 (86)					
	Depth	1,150 (45)					
Net Weight	kg (lb)	860 (1,896)	1,720 (3,792)	2,580 (5,688)	3,440 (7,584)	4,300 (9,480)	5,160 (11,376)
Gross Weight	kg (lb)	880 (1,940)	1,760 (3,880)	2,640 (5,820)	3,520 (7,760)	4,400 (9,700)	5,280 (11,640)
Operating Weight	kg (lb)	870 (1,918)	1,740 (3,836)	2,610 (5,754)	3,480 (7,672)	4,350 (9,590)	5,220 (11,508)
Refrigerant	Type	R410A					
	Charge	kg (lb)	26.3 (58)	52.6 (116)	78.9 (174)	105.2 (232)	131.5 (290)

Arbitrary combination up to 16 modules

Notes:

- Unit dimension is taken assuming units is stacked front facing the back and with installation clearance
- Nominal cooling capacity are based on the conditions below:

Mode		Cooling
Evaporator	Leaving Water Temperature	7°C
Condenser	Ambient Temperature	35°C DB / 24° C WB
Nominal Flow Rate		0.172 m³/h.kW

- Nominal water flow rate and pressure drop is based on series installation method.
- All specifications are subjected to change by the manufacturer without prior notice.

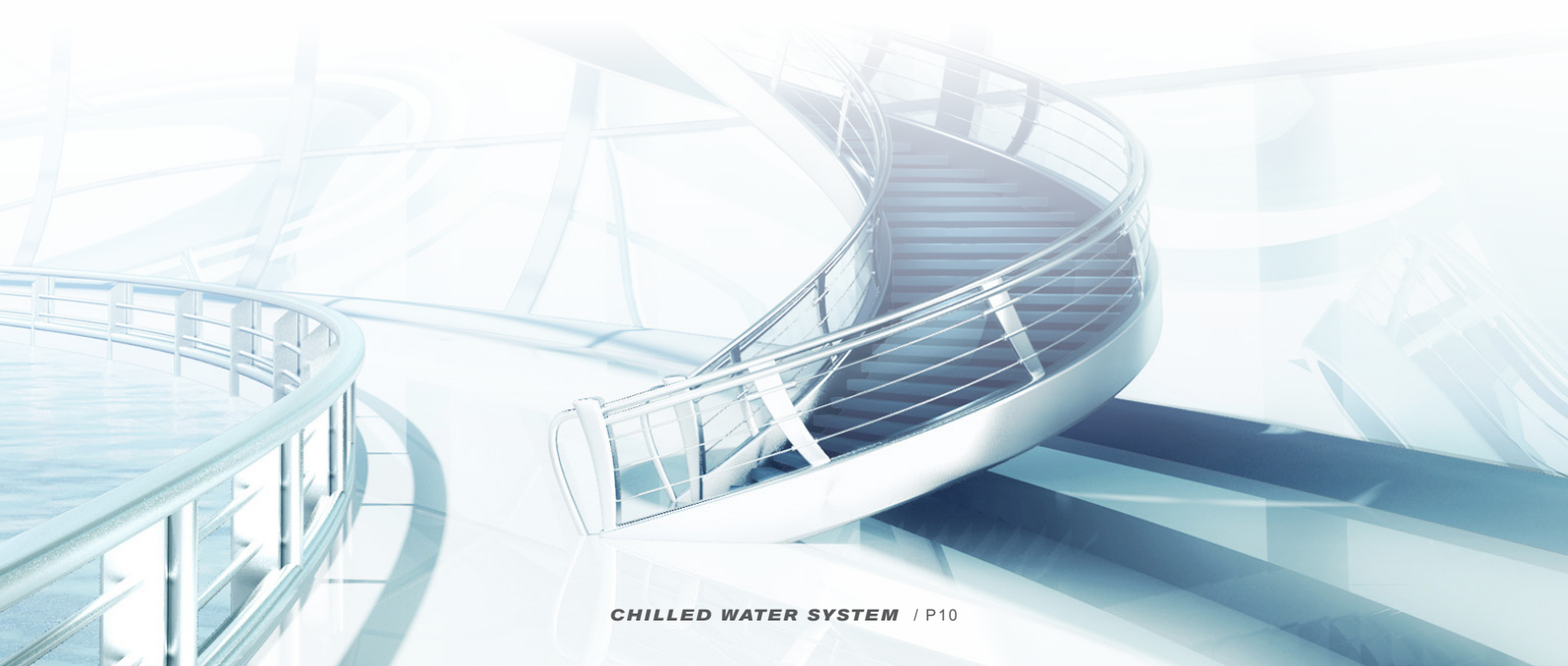

Specifications

A5MAC 450D - A5MAC 2700D (R410A)

Model		A5MAC 450D	A5MAC 900D	A5MAC 1350D	A5MAC 1800D	A5MAC 2250D	A5MAC 2700D
Nominal Cooling Capacity	BTU/h	460,700	921,300	1,382,000	1,842,600	2,303,200	2,763,900
	kW	135	270	405	540	675	810
Nominal Total Input Power	kW	40.3	80.6	120.9	161.2	201.5	241.8
Nominal Running Current	A	76.1	152.2	228.3	304.4	380.5	456.6
EER	BTU/h/W	11.40					
COP	W/W	3.35					
Power Source	V/Ph/Hz	380~415 / 3 / 50					
Refrigerant Control		EXV					
Sound Pressure Level	dBA	69	72	73.8	75	76	76.8
Nominal Water Flow Rate	m³/h	23.2	46.4	69.6	92.8	116	139.2
Nominal Water Pressure Drop Per Unit	kPa	48					
Pipe	Type	RC (INTERNAL TAPPER)					
	Size	mm (in) 63.5 (2 - 1/2)					
Unit Dimension	Height	mm (in) 2,300 (90)					
	Width	mm (in) 2,100 (83)					
	Depth	1,100 (43)	2,744 (108)	4,388 (173)	6,032 (237)	7,676 (302)	9,320 (367)
Packing Dimension (Individual)	Height	mm (in) 2,430 (96)					
	Width	mm (in) 2,175 (86)					
	Depth	mm (in) 1,150 (45)					
Net Weight	kg (lb)	940 (2,072)	1,880 (4,144)	2,820 (6,216)	3,760 (8,288)	4,700 (10,360)	5,640 (12,432)
Gross Weight	kg (lb)	960 (2,116)	1,920 (4,232)	2,880 (6,348)	3,840 (8,464)	4,800 (10,580)	5,760 (12,696)
Operating Weight	kg (lb)	950 (2,094)	1,900 (4,188)	2,850 (6,282)	3,800 (8,376)	4,750 (10,470)	5,700 (12,564)
Refrigerant	Type	R410A					
	Charge	kg (lb)	30.6 (67)	61.2 (135)	91.8(203)	122.4 (270)	153 (337)

Arbitrary combination up to 16 modules

Notes:

- Unit dimension is taken assuming units is stacked front facing the back and with installation clearance
- Nominal cooling capacity are based on the conditions below:

Mode		Cooling
Evaporator	Leaving Water Temperature	7°C
Condenser	Ambient Temperature	35°C DB / 24° C WB
Nominal Flow Rate		0.172 m³/h.kW

- Nominal water flow rate and pressure drop is based on series installation method.
- All specifications are subjected to change by the manufacturer without prior notice.

Specifications

A5MAC 1000D - 6000D (R410A)

Model		A5MAC 1000D	A5MAC 2000D	A5MAC 3000D	A5MAC 4000D	A5MAC 5000D	A5MAC 6000D
Nominal Cooling Capacity	BTU/h	1,006,600	2,013,200	3,019,800	4,026,400	5,033,000	6,039,500
	kW	295	590	885	1180	1475	1770
Nominal Total Input Power	kW	92.2	184.4	276.6	368.8	461	553.2
Nominal Running Current	A	168.5	337	505.5	674	842.5	1011
EER	BTU/h/W	10.9					
	W/W	3.20					
Power Source	V/Ph/Hz	380~415 / 3 / 50					
Refrigerant Control		EXV					
Sound Pressure Level	dBA	75	78	79.8	81	82	82.8
Nominal Water Flow Rate	m³/h	50.7	101.4	152.1	202.8	253.5	304.2
Nominal Water Pressure Drop Per Unit	kPa	40					
Pipe	Type	Clamp Type					
	Size	76.2 (3)					
Unit Dimension	Height	2360 (93)					
	Width	2200 (87)					
	Depth	2,230 (88)	5,460 (215)	8,690 (342)	11,920 (469)	15,150 (596)	18,380 (724)
Packing Dimension (Individual)	Height	2,490 (98)					
	Width	2,250 (93)					
	Depth	2,250 (93)					
Net Weight	kg (lb)	1,730 (3,814)	3,460 (7,628)	5,190 (11,442)	6,920 (15,256)	8,650 (19,070)	10,380 (22,884)
Gross Weight	kg (lb)	1,800 (3,968)	3,600 (7,937)	5,400 (11,905)	7,200 (15,873)	9,000 (19,842)	10,800 (23,810)
Operating Weight	kg (lb)	1,760 (3,880)	3,520 (7,760)	5,280 (11,640)	7,040 (15,521)	8,800 (19,401)	10,560 (23,281)
Refrigerant	Type	R410A					
	Charge	kg (lb)	58 (127.9)	116 (256)	174 (384)	232 (511)	290 (639)

Arbitrary combination up to 16 modules

Notes:

- Unit dimension is taken assuming units is stacked front facing the back and with installation clearance.
- Nominal cooling capacity are based on the conditions below:

Mode		Cooling
Evaporator	Leaving Water Temperature	7°C
Condenser	Ambient Temperature	35°C DB / 24°C WB
Nominal Flow Rate		0.172 m³/h.kW

- Nominal water flow rate and pressure drop is based on series installation method.
- All specifications are subjected to change by the manufacturer without prior notice.
- Sound pressure level is measured based on distance from chiller to receiver = 1.0m.

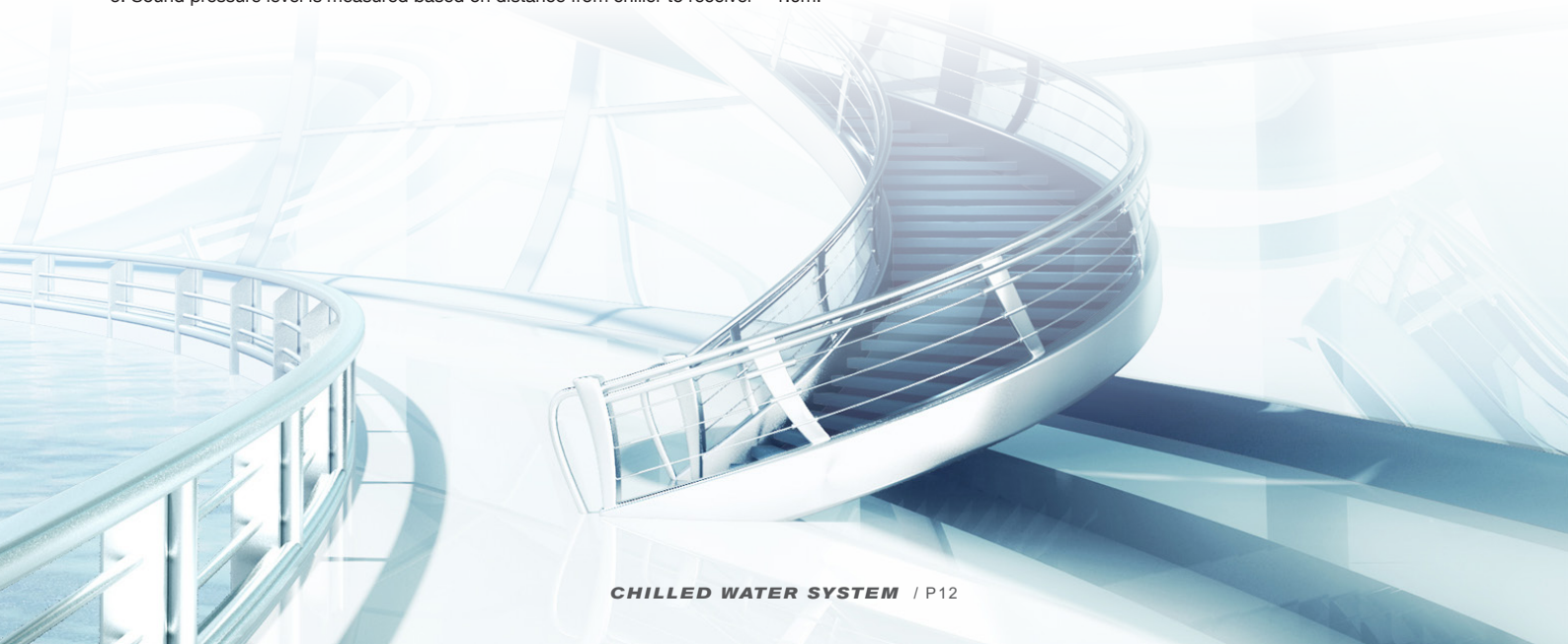

Water Cooled Modular Chilled Series



Model		A5MWC 020BR-320BR	A5MWC 030BR-480BR	A5MWC 040BR-640BR
Cooling Capacity	kW	69 - 1104	101 - 1616 110 - 1760 (High EER Model)	140 - 2240 145 - 2320 (High EER Model)
Refrigerant		R410A		

Features

Modular Design

The modular chiller allows for combination of up to 16 base modules unit where each module can be connected to form a much larger system.

Base Module	A5MWC 20BR	A5MWC 30BR	A5MWC 40BR
Modular Chiller B Series	A5MWC 40BR	A5MWC 60BR	A5MWC 80BR
	A5MWC 60BR	A5MWC 90BR	A5MWC 120BR
	A5MWC 80BR	A5MWC 120BR	A5MWC 160BR
	A5MWC 100BR	A5MWC 150BR	A5MWC 200BR
	A5MWC 120BR	A5MWC 180BR	A5MWC 240BR

*Arbitrary combination up to 16 modules

Change Whenever Need

It is unnecessary to fix the central air-conditioning equipment for one time to be certain combination. Instead, other modules and corresponding equipment can be added as required by the growth of the occupants. It helps to save the initial investment and the operation cost.

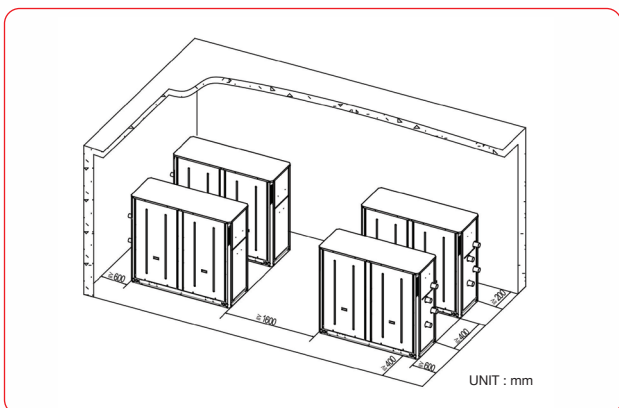

Reliable Operation

The fault of any compressor or the maintenance and care of any unit will not affect the normal operation of other units.

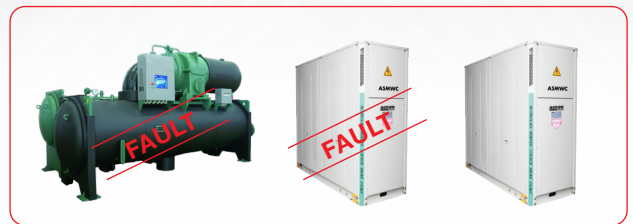

Ez-Comm for ModBus Communication

The Ez-Comm is a data converter that coordinates Acson modular chiller unit control system and controls inter-system communications based on the ModBus communication protocol. It automatically converts the internal communication protocol of Acson modular chiller unit into the ModBus communication protocol to ensure that the unit is connected to the BAS system that is based on the ModBus RTU communication protocol and uses the RS485 communication mode.

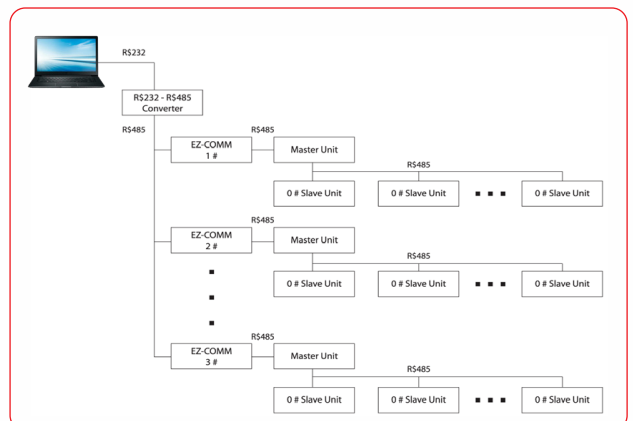

Specifications

A5MWC 20BR - A5MWC 120BR

Model			A5MWC 20BR	A5MWC 40BR	A5MWC 60BR	A5MWC 80BR	A5MWC 100BR	A5MWC 120BR
Nominal Cooling Capacity	BTU/h		235,400	470,800	706,200	941,600	1,177,000	1,412,400
	kW		69.00	138.00	207.00	276.00	345.00	414.00
Nominal Total Input Power	kW		15.50	31.00	46.50	62.00	77.50	93.00
Nominal Running Current	A		29.3	58.6	87.9	117.2	146.5	175.8
EER	BTU/h/W		15.19					
	W/W		4.45					
Power Source	V/Ph/Hz		380 - 415 / 3 / 50					
Refrigerant Control			EXV					
Sound Pressure Level	dBA		63.5	66.5	68.3	69.5	70.5	71.3
Nominal Water Flow Rate	Evaporator	m ³ /h	11.9	23.8	35.7	47.6	59.5	71.4
	Condenser	m ³ /h	14.8	29.6	44.4	59.2	74	88.8
Nominal Water Pressure Drop Per Unit	Evaporator	kPa	36					
	Condenser	kPa	56					
Pipe	Type		R (EXTERNAL TAPER)					
	Size	mm (in)	50.8 (2)					
Unit Dimension	Height	mm (in)	1,600 (63)					
	Width	mm (in)	1,800 (71)					
	Depth	mm (in)	650 (26)	1,750 (69)	2,850 (112)	3,950 (156)	5,050 (199)	6,150 (242)
Packing Dimension (Individual)	Height	mm (in)	1,750 (69)					
	Width	mm (in)	1,915 (75)					
	Depth	mm (in)	715 (28)					
Net Weight	kg (lb)	490 (1,080)	980 (2,161)	1,470 (3,241)	1,960 (4,321)	2,450 (5,401)	2,940 (6,482)	
Gross Weight	kg (lb)	510 (1,124)	1,020 (2,249)	1,530 (3,373)	2,040 (4,497)	2,550 (5,622)	3,060 (6,746)	
Operating Weight	kg (lb)	539 (1,078)	1,078 (2,377)	1,617 (3,565)	2,156 (4,753)	2,695 (5,941)	3,234 (7,130)	
Refrigerant	Type		R410A					
	Charge	kg (lb)	5.8 (13)	11.6 (26)	17.4 (38)	23.2 (51)	29 (64)	34.8 (77)

Arbitrary combination up to 16 modules

Notes:

- Unit dimension is taken assuming units is stacked front facing the back and with installation clearance
- Nominal cooling capacity are based on the conditions below:

Criteria		Cooling
Evaporator	Leaving Water Temperature	7°C
	Nominal Flow Rate	0.172 m ³ /h.kW
Condenser	Entering Water Temperature	30°C
	Nominal Flow Rate	0.215 m ³ /h.kW

- Nominal water flow rate and pressure drop is based on series installation method.
- All specifications are subjected to change by the manufacturer without prior notice.

Specifications

A5MWC 30BR - A5MWC 180BR (FBAE-Standard Efficiency)

Model			A5MWC 30BR	A5MWC 60BR	A5MWC 90BR	A5MWC 120BR	A5MWC 150BR	A5MWC 180BR
Nominal Cooling Capacity	BTU/h		344,600	689,200	1,033,800	1,378,400	1,723,000	2,067,600
	kW		101.00	202.00	303.00	404.00	505.00	606.00
Nominal Total Input Power	kW		23.70	47.40	71.10	94.80	118.50	142.20
Nominal Running Current	A		44	88	132	176	220	264
EER	BTU/h/W		14.54					
	W/W		4.26					
Power Source	V/Ph/Hz		380 - 415 / 3 / 50					
Refrigerant Control			EXV					
Sound Pressure Level	dB(A)		62	65	66.8	68	69	69.8
Nominal Water Flow Rate	Evaporator	m ³ /h	17.4	34.8	52.2	69.6	87	104.4
	Condenser	m ³ /h	21.7	43.4	65.1	86.8	108.5	130.2
Nominal Water Pressure Drop Per Unit	Evaporator	kPa	28					
	Condenser	kPa	47					
Pipe	Type		R (EXTERNAL TAPER)					
	Size	mm (in)	50.8 (2)					
Unit Dimension	Height	mm (in)	1,600 (63)					
	Width	mm (in)	1,800 (71)					
	Depth	mm (in)	650 (26)	1,750 (69)	2,850 (112)	3,950 (156)	5,050 (199)	6,150 (242)
Packing Dimension (Individual)	Height	mm (in)	1,750 (69)					
	Width	mm (in)	1,915 (75)					
	Depth	mm (in)	715 (28)					
Net Weight	kg (lb)	630 (1,389)	1,260 (2,778)	1,890 (4,167)	2,520 (5,556)	3,150 (6,945)	3,780 (8,333)	
Gross Weight	kg (lb)	650 (1,433)	1,300 (2,866)	1,950 (4,299)	2,600 (5,732)	3,250 (7,165)	3,900 (8,598)	
Operating Weight	kg (lb)	693 (1,528)	1,386 (3,056)	2,079 (4,583)	2,772 (6,111)	3,465 (7,639)	4,158 (9,167)	
Refrigerant	Type		R410A					
	Charge	kg (lb)	8.7 (19)	17.4 (38)	26.1 (58)	34.8 (77)	43.5 (96)	52.2 (115)

Arbitrary combination up to 16 modules

Notes:

- Unit dimension is taken assuming units is stacked front facing the back and with installation clearance
- Nominal cooling capacity are based on the conditions below:

Criteria		Cooling
Evaporator	Leaving Water Temperature	7°C
	Nominal Flow Rate	0.172 m ³ /h.kW
Condenser	Entering Water Temperature	30°C
	Nominal Flow Rate	0.215 m ³ /h.kW

- Nominal water flow rate and pressure drop is based on series installation method.
- All specifications are subjected to change by the manufacturer without prior notice.

Specifications

A5MWC 40BR - A5MWC 240BR (FBAE-Standard Efficiency)

Model			A5MWC 40BR	A5MWC 80BR	A5MWC 120BR	A5MWC 160BR	A5MWC 200BR	A5MWC 240BR
Nominal Cooling Capacity	BTU/h		477,700	955,400	1,433,100	1,910,800	2,388,500	2,866,200
	kW		140.00	280.00	420.00	560.00	700.00	840.00
Nominal Total Input Power	kW		31.50	63.00	94.50	126.00	157.50	189.00
Nominal Running Current	A		59.7	119.4	179.1	238.8	298.5	358.2
EER	BTU/h/W		15.17					
	W/W		4.44					
Power Source	V/Ph/Hz		380 - 415 / 3 / 50					
Refrigerant Control			EXV					
Sound Pressure Level	dBA		66	69	70.8	72	73	73.8
Nominal Water Flow Rate	Evaporator	m ³ /h	24.1	48.2	72.3	96.4	120.5	144.6
	Condenser	m ³ /h	30.1	60.2	90.3	120.4	150.5	180.6
Nominal Water Pressure Drop Per Unit	Evaporator	kPa	45					
	Condenser	kPa	68					
Pipe	Type		R (EXTERNAL TAPER)					
	Size	mm (in)	63.5 (2 - 1/2)					
Unit Dimension	Height	mm (in)	1,600 (63)					
	Width	mm (in)	1,800 (71)					
	Depth	mm (in)	650 (26)	1,750 (69)	2,850 (112)	3,950 (156)	5,050 (199)	6,150 (242)
Packing Dimension (Individual)	Height	mm (in)	1,750 (69)					
	Width	mm (in)	1,915 (75)					
	Depth	mm (in)	715 (28)					
Net Weight	kg (lb)	745 (1,642)	1,490 (3,285)	2,235 (4,927)	2,980 (6,570)	3,725 (8,212)	4,470 (9,855)	
Gross Weight	kg (lb)	765 (1,687)	1,530 (3,373)	2,295 (5,060)	3,060 (6,746)	3,825 (8,433)	4,590 (10,119)	
Operating Weight	kg (lb)	820 (1,808)	1,640 (3,616)	2,460 (5,423)	3,280 (7,231)	4,100 (9,039)	4,920 (10,847)	
Refrigerant	Type		R410A					
	Charge	kg (lb)	11.6 (26)	23.2 (51)	34.8 (77)	46.4 (102)	58 (128)	69.6 (153)

Arbitrary combination up to 16 modules

Notes:

- Unit dimension is taken assuming units is stacked front facing the back and with installation clearance
- Nominal cooling capacity are based on the conditions below:

Criteria		Cooling
Evaporator	Leaving Water Temperature	7°C
	Nominal Flow Rate	0.172 m ³ /h.kW
Condenser	Entering Water Temperature	30°C
	Nominal Flow Rate	0.215 m ³ /h.kW

- Nominal water flow rate and pressure drop is based on series installation method.
- All specifications are subjected to change by the manufacturer without prior notice.

Specifications

A5MWC 30BR - A5MWC 180BR (FAAE-High Efficiency)

Model			A5MWC 30BR	A5MWC 60BR	A5MWC 90BR	A5MWC 120BR	A5MWC 150BR	A5MWC 180BR
Nominal Cooling Capacity	BTU/h		375,300	750,600	1,125,900	1,501,200	1,876,500	2,251,800
	kW		110.00	220.00	330.00	440.00	550.00	660.00
Nominal Total Input Power	kW		23.90	47.80	71.70	95.60	119.50	143.40
Nominal Running Current	A		43.5	87	130.5	174	217.5	261
EER	BTU/h/W		15.7					
	W/W		4.60					
Power Source	V/Ph/Hz		380-415 / 3 / 50					
Refrigerant Control			EXV					
Sound Pressure Level	dBA		62	65	66.8	68	69	69.8
Nominal Water Flow Rate	Evaporator	m ³ /h	18.9	37.8	56.7	75.6	94.5	113.4
	Condenser	m ³ /h	23.7	47.4	71.1	94.8	118.5	142.2
Nominal Water Pressure Drop Per Unit	Evaporator	kPa	41					
	Condenser	kPa	68					
Pipe	Type		R (EXTERNAL TAPER)					
	Size	mm (in)	63.5 (2 - 1/2)					
Unit Dimension	Height	mm (in)	1,600 (63)					
	Width	mm (in)	1,800 (71)					
	Depth	mm (in)	650 (26)	1,750 (69)	2,850 (112)	3,950 (156)	5,050 (199)	6,150 (242)
Packing Dimension (Individual)	Height	mm (in)	1,750 (69)					
	Width	mm (in)	1,915 (75)					
	Depth	mm (in)	715 (28)					
Net Weight	kg (lb)	655 (1,444)	1,310 (2,888)	1,965 (4,332)	2,620 (5,776)	3,275 (7,220)	3,930 (8,664)	
Gross Weight	kg (lb)	670 (1,477)	1,340 (2,954)	2,010 (4,431)	2,680 (5,908)	3,350 (7,385)	4,020 (8,863)	
Operating Weight	kg (lb)	720 (1,587)	1,440 (3,175)	2,160 (4,762)	2,880 (6,349)	3,600 (7,937)	4,320 (9,524)	
Refrigerant	Type		R410A					
	Charge	kg (lb)	10.2 (22)	20.4 (45)	30.6 (67)	40.8 (90)	51.0 (112)	61.2 (135)

Arbitrary combination up to 16 modules

Notes:

- Unit dimension is taken assuming units is stacked front facing the back and with installation clearance
- Nominal cooling capacity are based on the conditions below:

Criteria		Cooling
Evaporator	Leaving Water Temperature	7°C
	Nominal Flow Rate	0.172 m ³ /h.kW
Condenser	Entering Water Temperature	30°C
	Nominal Flow Rate	0.215 m ³ /h.kW

- Nominal water flow rate and pressure drop is based on series installation method.
- All specifications are subjected to change by the manufacturer without prior notice.

Specifications

A5MWC 40BR - A5MWC 240BR (FAAE-High Efficiency)

Model			A5MWC 40BR	A5MWC 80BR	A5MWC 120BR	A5MWC 160BR	A5MWC 200BR	A5MWC 240BR
Nominal Cooling Capacity	BTU/h		494,700	989,400	1,484,100	1,978,800	2,473,500	2,968,200
	kW		145.00	290.00	435.00	580.00	725.00	870.00
Nominal Total Input Power	kW		31.10	62.20	93.30	124.40	155.50	186.60
Nominal Running Current	A		56.7	113.4	170.1	226.8	283.5	340.2
EER	BTU/h/W		15.91					
	W/W		4.66					
Power Source	V/Ph/Hz		380-415 / 3 / 50					
Refrigerant Control			EXV					
Sound Pressure Level	dBA		66	69	70.8	72	73	73.8
Nominal Water Flow Rate	Evaporator	m³/h	24.9	49.8	74.7	99.6	199.2	398.4
	Condenser	m³/h	31.2	62.4	93.6	124.8	249.6	499.2
Nominal Water Pressure Drop Per Unit	Evaporator	kPa	48					
	Condenser	kPa	45					
Pipe	Type		R (EXTERNAL TAPER)					
	Size	mm (in)	63.5 (2 - 1/2)					
Unit Dimension	Height	mm (in)	1,600 (63)					
	Width	mm (in)	1,800 (71)					
	Depth	mm (in)	650 (26)	1,750 (69)	2,850 (112)	3,950 (156)	5,050 (199)	6,150 (242)
Packing Dimension (Individual)	Height	mm (in)	1,750 (69)					
	Width	mm (in)	1,915 (75)					
	Depth	mm (in)	715 (28)					
Net Weight	kg (lb)	804 (1,773)	1,608 (3,545)	2,412 (5,318)	3,216 (7,090)	4,020 (8,863)	4,824 (10,635)	
Gross Weight	kg (lb)	820 (1,808)	1,640 (3,616)	2,460 (5,423)	3,280 (7,231)	4,100 (9,039)	4,920 (10,847)	
Operating Weight	kg (lb)	885 (1,951)	1,770 (3,902)	2,655 (5,853)	3,540 (7,804)	4,425 (9,755)	5,310 (11,707)	
Refrigerant	Type		R410A					
	Charge	kg (lb)	14 (31)	28 (62)	42 (93)	56 (123)	70 (154)	84 (185)

Arbitrary combination up to 16 modules



Notes:

- Unit dimension is taken assuming units is stacked front facing the back and with installation clearance
- Nominal cooling capacity are based on the conditions below:

Criteria		Cooling
Evaporator	Leaving Water Temperature	7°C
	Nominal Flow Rate	0.172 m³/h.kW
Condenser	Entering Water Temperature	30°C
	Nominal Flow Rate	0.215 m³/h.kW

- Nominal water flow rate and pressure drop is based on series installation method.
- All specifications are subjected to change by the manufacturer without prior notice.

Air Cooled Mini Chiller Series

Model		 A5ACY030ER-40ER	 A5ACY050ER-80ER	 A5ACY100ER-150ER
Cooling capacity	kW	9.4 - 11.40	14.6 - 24.90	28.80 - 40.00

*Picture is for illustration purpose only.

Features

All in One Unit

The mini chiller is fully integrated and equipped with key hydronic components such as expansion tank, water tank, brazed plate heat exchanger and water circulating pump. The all in one concept will ease the job of installation.

Wide Operating Range

The unit operates normally in the ambient temperature range of -15°C to 48°C and supplies outlet water in the wide temperature range of 5°C to 55°C.

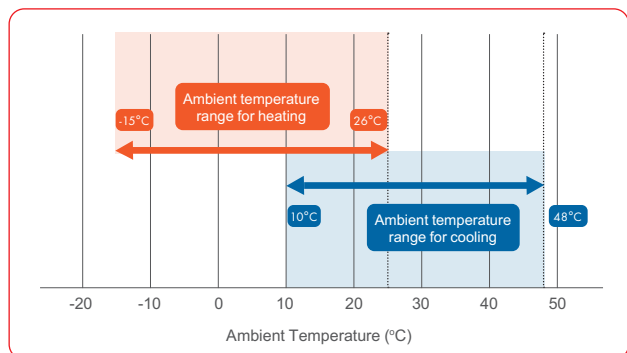

Integrated Design

The whole system is provide with a complete set of accessories Installation can be easily completed by connecting the water pipe to the terminal.

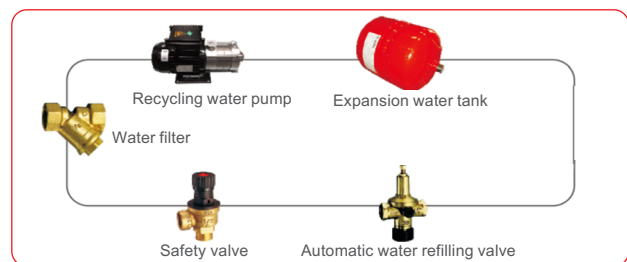

Accessory of the water system	Standard Built-In	Recycling pump, expansion tank
	Supplied accessories	water filter, automatic water refilling valve, safety valve, communication cable, drain joint and PE gasket

Power is Nothing Without Control

An user friendly and versatile wired controller is equipped with every mini chiller

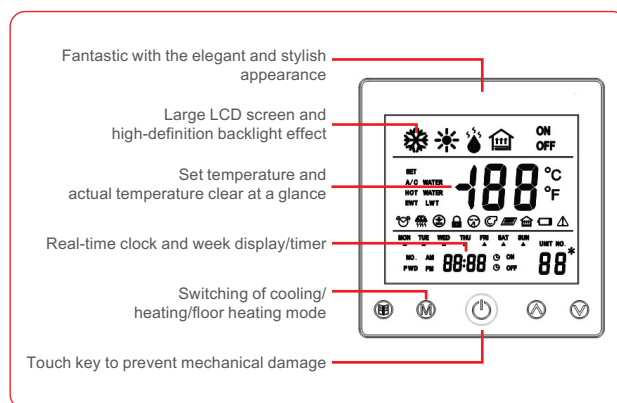

Protection

- Anti-Freeze Heater
The BPHE (Brazed Plate Heat Exchanger) has a strip heater around it to prevent from water freezing
- Anti-Freeze Sensor
Signal is sent from the anti-freeze sensor to cut out the compressor if the water temperature becomes too low to prevent BPHE from freezing.

Unique disassembly-free design

The metal plate of the unit and metal plate at the water pipe are separated from each other and hence, the user does not require to remove the water pipe during maintenance. Users need not remove the metal plate during the wire connection process as well.

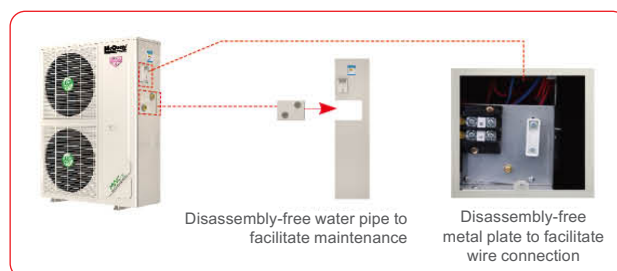

Specifications

A5ACY30ER-A5ACY150ER (A5MAC-ER) (R410A) - Inverter Series

Model		A5ACY030ER	A5ACY040ER	A5ACY050ER	A5ACY060ER	
Nominal Cooling Capacity	BTU/h	32,100	38,900	49,800	57,300	
	kW	9.40	11.40	14.60	16.80	
Nominal Total Input Power	kW	3.00	3.90	4.60	5.70	
Nominal Running Current	A	13.8	18	21.0	26.4	
EER	BTU/h/W	10.70	9.97	10.83	10.05	
COP	W/W	3.13	2.92	3.17	2.95	
IPLV*		4.21	4.23	4.16	4.13	
Power Source	V/Ph/Hz	220 - 240 / 1 / 50				
Refrigerant Control		EXV				
Sound Pressure Level	dBA	56/53/46	56/53/46	58/55/48	58/55/48	
Nominal Water Flow Rate	m ³ /h	1.62	1.96	2.51	2.89	
Nominal Water Pressure Drop (Including Strainer)	kPa	17	19	27	27	
Available Pressure Head	m	15	14	18	22	
Pipe	Type	RC (INTERNAL TAPER)				
	Size	mm (in) 25.4 (1)				
Expansion Tank	Size	L	3	3	5	5
Unit Dimension	Height	mm (in)	1,010 (40)		1,362 (54)	
	Width	mm (in)	950 (37)		995 (39)	
	Depth	mm (in)	397 (16)		395 (16)	
Packing Dimension	Height	mm (in)	1,175 (46)		1,530 (60)	
	Width	mm (in)	1,010 (40)		1,086 (43)	
	Depth	mm (in)	498 (20)		512 (20)	
Net Weight	kg (lb)	109 (240)	110 (243)	146 (322)	148 (326)	
Refrigerant	Type	R410A				
	Charge	kg (lb)	2.9 (6.4)	3 (6.6)	4 (8.8)	

Model		A5ACY070ER	A5ACY080ER	A5ACY100ER	A5ACY120ER	A5ACY150ER	
Nominal Cooling Capacity	BTU/h	67,600	85,000	98,300	114,300	136,500	
	kW	19.80	24.90	28.80	33.50	40.00	
Nominal Total Input Power	kW	6.70	8.60	9.50	10.40	13.90	
Nominal Running Current	A	10.3	13.2	15.2	16.6	22.3	
EER	BTU/h/W	10.09	9.88	10.35	10.99	9.82	
COP	W/W	2.96	2.90	3.03	3.22	2.88	
IPLV*		4.15	4.23	4.90	4.71	4.45	
Power Source	V/Ph/Hz	380 - 415 / 3 / 50					
Refrigerant Control		EXV					
Sound Pressure Level	dBA	59/54/52	60/56/52	63	64	65	
Nominal Water Flow Rate	m ³ /h	3.41	4.28	4.95	5.76	6.88	
Nominal Water Pressure Drop (Including Strainer)	kPa	34	40	27	32	65	
Available Pressure Head	m	24	22	25	22	18	
Pipe	Type	RC (INTERNAL TAPER)		G (EXTERNAL AND INTERNAL PARALLEL)			
	Size	mm (in) 31.8 (1 - 1/4)					
Expansion Tank	Size	L	5	5	8	8	8
Unit Dimension	Height	mm (in)	1,362 (54)		1,780 (70)		
	Width	mm (in)	995 (39)		990 (39)	1,350 (53)	
	Depth	mm (in)	395 (16)		844 (33)		
Packing Dimension	Height	mm (in)	1,530 (60)		1,970 (78)		
	Width	mm (in)	1,086 (43)		1,030 (41)	1,440 (57)	
	Depth	mm (in)	512 (20)		890 (35)		
Net Weight	kg (lb)	158 (348)	165 (364)	228 (503)	250 (551)	280 (617)	
Refrigerant	Type	R410A					
	Charge	kg (lb)	5.2 (11.5)	8 (17.6)	8.5 (18.7)	9.1 (20.1)	

Notes:

- Unit dimension is taken assuming units is stacked front facing the back and with installation clearance.
- Unit have built in water pump and expansion tank. However, strainer, safety valve, water filling valve and wired controller need to be install on site.
- Nominal cooling capacity are based on the conditions below:

Mode		Cooling
Evaporator	Leaving Water Temperature	7°C
Condenser	Ambient Temperature	35°C DB / 24° C WB
Nominal Flow Rate		0.172 m ³ /h.kW

- All specifications are subjected to change by the manufacturer without prior notice.

Chilled Water Fan Coil Units Line-up



A wide range of fan coil units ranging from residential use to industrial application is available for different needs. Each model comes with their own unique features and advantages.

The available chilled water fan coil units are:

- Wall Mounted JW
- Ceiling Cassette CW/ EW Series
- Ceiling Mounted EW Series
- Ducted Blower BW Series
- Ducted Blower FW Series
- Ceiling Concealed VW Series
- Ceiling Concealed CW Series
- Ceiling Concealed GW Series
- Ceiling Concealed FWD Series
- Double Skin Ceiling Concealed CW Series

Power is Nothing Without Control

SLM9

The Chilled Water Fan Coil Unit is supplied with SLM9 micro computer thermostat as standard wired controller. This wired controller comes with a LCD screen with every information of the unit easily visible. It is adapted to fan coil and electromechanical valve's control.

*Applicable for certain model



1. SWING Button

Swing at your command or fix the louver at your preferred position.

2. MODE Button

Different Mode for different ambient - Cool, Dry, and Fan.

3. DELAY TIMER Button

Delay the "OFF" timer function by maximum of 2 hour.

4. FAN Button

Control your airflow to Low, Mid, High or Auto to let your unit do the thinking.

5. TIMER Button

Turn on or off the unit automatically with its built in timer. Maximum of 2 ON and 2 OFF timers.

6. LCD Display

Every information on the unit vividly display in LCD screen.

7. TEMPERATURE Button

Set the temperature according to your preferences.

8. SLEEP Button

The sleep mode gradually increase the room temperature to ensure a comfortable and mellow sleeping environment.

9. ON/OFF POWER Button

The Power Button turn the unit ON or OFF.

10. Real Time Clock (RTC)

Set the real time clock.

Specifications

AWM07JW - AWM 25JW (Wall Mounted)



Model			AWM07JW	AWM10JW	AWM 15JW	AWM 20JW	AWM 25JW	
Nominal Cooling Capacity	BTU/h		8,300	9,200	11,300	15,500	18,000	
	kW		2.43	2.7	3.31	4.54	5.28	
Nominal Total Input Power	kW		0.031	0.032	0.042	0.053	0.072	
Nominal Operating Current	A		0.19	0.2	0.21	0.29	0.34	
Power Source	V/Ph/Hz		220 ~ 240 / 1 / 50					
Control	Air Discharge		AUTOMATIC LOUVER (UP & DOWN)					
	Operation		WIRED (OPTIONAL) OR WIRELESS CONTROLLER					
Air Flow Rate	High	l/s (CFM)	123 (260)	132 (280)	175 (370)	241 (510)	293 (620)	
	Medium	l/s (CFM)	109 (230)	118 (250)	151 (320)	212 (450)	245 (520)	
	Low	l/s (CFM)	94 (200)	104 (220)	123 (260)	184 (390)	217 (460)	
	Quiet	l/s (CFM)	85 (180)	90 (190)	113 (240)	170 (360)	208 (440)	
Nominal Water Flow Rate	USGPM		1.85	2.03	2.51	3.43	4.01	
	liters/min		7.00	7.68	9.50	13.00	15.18	
Head Loss (Cooling)	kPa		34	24	31	30	36	
Maximum Working Pressure (Cooling)	kPa		1608					
Surface Air Velocity	m/s		0.68	0.74	0.97	0.83	1.01	
Sound Pressure Level (H/M/L/Q)	dBA		34 / 29 / 25 / 24	35 / 30 / 25 / 24	42 / 39 / 32 / 29	42 / 38 / 34 / 32	46 / 42 / 39 / 37	
Unit Dimension	Height	mm (in)	288 (11)				310 (12)	
	Width	mm (in)	800 (31)				1,065 (42)	
	Depth	mm (in)	206 (8)				224 (9)	
Packing Dimension	Height	mm (in)	344 (14)				386 (15)	
	Width	mm (in)	874 (34)				1,136 (45)	
	Depth	mm (in)	274 (11)				314 (12)	
Unit Weight	kg (lb)		9 (20)				14 (31)	
Condensate Drain Pipe Size	mm (in)		19.05 (3/4)					
Pipe Connection	Type		BSP FEMALE THREAD ADAPTOR					
	Size	mm (in)	12.7 (1/2)					
Filter	Type		WASHABLE SARANET FILTER					
	Quantity	pcs	2					
Casing	Colour		WHITE					

Notes:

1. Nominal cooling capacity are based on the conditions below:

Mode	Cooling
Entering Air Temperature	27°C DB / 19°C WB
Entering Water Temperature	7°C
Leaving Water Temperature	12°C

2. Sound measurement position is 1m in front and 0.8m below the vertical line of the unit.

3. All specifications are subjected to change by the manufacturer without prior notice.

Specifications

ACK 10CW - ACK 20CW (Ceiling Cassette C Series)



Model			ACK 10CW	ACK 15CW	ACK 20CW
Nominal Cooling Capacity	BTU/h		8,500	14,000	15,500
	kW		2.49	4.1	4.54
Nominal Total Input Power	kW		0.063	0.064	0.079
Nominal Operating Current	A		0.28	0.28	0.35
Power Source	V/Ph/Hz		220 ~ 240 / 1 / 50		
Control	Air Discharge		AUTOMATIC LOUVER (UP & DOWN)		
	Operation		WIRED (OPTIONAL) OR WIRELESS CONTROLLER		
Air Flow Rate	High	l/s (CFM)	179 (380)	189 (400)	208 (440)
	Medium	l/s (CFM)	137 (290)	146 (310)	156 (330)
	Low	l/s (CFM)	109 (230)	104 (220)	132 (280)
Nominal Water Flow Rate	USGPM		2.03	3.43	3.57
	liters/min		7.68	12.98	13.51
Head Loss (Cooling)	kPa		19.3	26.9	28.8
Maximum Working Pressure (Cooling)	kPa		1608		
Surface Air Velocity	m/s		0.74	0.74	0.82
Sound Pressure Level (H/M/L)	dBA		42 / 35 / 29	45 / 38 / 30	48 / 40 / 36
Unit Dimension	Height	mm (in)	250 (9.84)		
	Width	mm (in)	570 (22.44)		
	Depth	mm (in)	570 (22.44)		
Unit Dimension - With Panel	Height	mm (in)	295 (11.61)		
	Width	mm (in)	640 (25.2)		
	Depth	mm(in)	640 (25.2)		
Packing Dimension	Height	mm (in)	316 (12.44)		
	Width	mm (in)	630 (24.8)		
	Depth	mm (in)	630 (24.8)		
Panel Packing Dimension	Height	mm (in)	126 (4.96)		
	Width	mm (in)	700 (27.56)		
	Depth	mm (in)	726 (28.58)		
Unit + Panel Weight	kg (lb)		15 + 3 (33 + 7)	17 + 3 (37 + 7)	17 + 3 (37 + 7)
Condensate Drain Pipe Size	mm (in)		19.05 (3/4)		
Pipe Connection	Type		BSP FEMALE THREAD ADAPTOR		
	Size	mm (in)	19.05 (3/4)		
Filter	Type		WASHABLE SARANET FILTER		
	Quantity	pcs	1		
Casing	Colour		WHITE		

Notes:

1. Nominal cooling capacity are based on the conditions below:

Mode	Cooling
Entering Air Temperature	27°C DB / 19°C WB
Entering Water Temperature	7°C
Leaving Water Temperature	12°C

2. Sound measurement position is 1.4m below the face center of the air return of the unit.
 3. All specifications are subjected to change by the manufacturer without prior notice.

Specifications

ACK 20EW - ACK 50EW (Ceiling Cassette E Series)



Model			ACK 20EW	ACK 25EW	ACK 30EW	ACK 40EW	ACK 50EW
Nominal Cooling Capacity	BTU/h		21,000	25,000	30,000	38,000	43,000
	kW		6.15	7.33	8.79	11.14	12.6
Nominal Total Input Power	kW		0.095	0.126	0.167	0.186	0.227
Nominal Operating Current	A		0.44	0.55	0.74	0.85	1.03
Power Source	V/Ph/Hz		220 ~ 240 / 1 / 50				
Control	Air Discharge		4 WAY AUTOMATIC LOUVER (UP & DOWN)				
	Operation		WIRED (OPTIONAL) OR WIRELESS CONTROLLER				
Air Flow Rate	High	l/s (CFM)	354 (750)	406 (860)	420 (890)	472 (1,000)	538 (1,140)
	Medium	l/s (CFM)	293 (620)	330 (700)	340 (720)	396 (840)	472 (1,000)
	Low	l/s (CFM)	227 (480)	255 (540)	269 (570)	321 (680)	396 (840)
	Quiet	l/s (CFM)	151 (320)	179 (380)	198 (420)	255 (540)	330 (700)
Nominal Water Flow Rate	USGPM		4.71	5.59	6.69	8.45	9.6
	liters/min		17.83	21.17	25.29	31.94	36.29
Head Loss (Cooling)	kPa		20	37	22	44	53
Maximum Working Pressure (Cooling)	kPa		1608				
Surface Air Velocity	m/s		0.92	1.05	1.13	1.02	1.17
Sound Pressure Level (H/M/L/Q)	dBA		42 / 38 / 32 / 23	46 / 42 / 35 / 27	48 / 43 / 38 / 30	50 / 47 / 43 / 33	52 / 49 / 45 / 39
Unit Dimension	Height	mm (in)	265 (10.43)			300 (11.81)	
	Width	mm (in)	820 (32.28)				
	Depth	mm (in)	820 (32.28)				
Unit Dimension - With Panel	Height	mm (in)	340 (13.39)			375 (14.76)	
	Width	mm (in)	990 (38.98)				
	Depth	mm (in)	990 (38.98)				
Packing Dimension	Height	mm (in)	341 (13.43)			376 (14.80)	
	Width	mm (in)	916 (36.06)				
	Depth	mm (in)	916 (36.06)				
Panel Packing Dimension	Height	mm (in)	125 (4.92)				
	Width	mm (in)	1,020 (40.16)				
	Depth	mm (in)	1,020 (40.16)				
Unit + Panel Weight	kg (lb)		26 + 4 (57 + 9)		28 + 4 (62 + 9)	32 + 4 (71 + 9)	
Condensate Drain Pipe Size	mm (in)		19.05 (3/4)				
Pipe Connection	Type		BSP FEMALE THREAD ADAPTOR				
	Size	mm (in)	19.05 (3/4)				
Filter	Type		WASHABLE SARANET FILTER				
	Quantity	pcs	1				
Casing	Colour		WHITE				

Notes:

1. Nominal cooling capacity are based on the conditions below:

Mode	Cooling
Entering Air Temperature	27°C DB / 19°C WB
Entering Water Temperature	7°C
Leaving Water Temperature	12°C

2. Sound measurement position is 1.4m and up to 1.5m below the face center of the air return of the unit.

3. All specifications are subjected to change by the manufacturer without prior notice.

Specifications

ACM 15EW - ACM 50EW (Ceiling Mounted E Series)



Model			ACM 30EW	ACM 40EW	ACM 50EW
Nominal Cooling Capacity	BTU/h		25,000	34,000	47,000
	kW		7.33	9.96	13.77
Nominal Total Input Power	kW		0.148	0.197	0.225
Nominal Operating Current	A		0.65	0.87	0.99
Power Source	V/Ph/Hz		220 ~ 240 / 1 / 50		
Control	Air Discharge		AUTOMATIC LOUVER (UP & DOWN)		
	Operation		WIRED (OPTIONAL) OR WIRELESS CONTROLLER		
Air Flow Rate	High	l/s (CFM)	396 (840)	529 (1,120)	580 (1,230)
	Medium	l/s (CFM)	354 (750)	463 (980)	514 (1,090)
	Low	l/s (CFM)	311 (660)	406 (860)	467 (990)
Nominal Water Flow Rate	USGPM		5.77	7.71	10.17
	liters/min		21.85	29.19	38.53
Head Loss (Cooling)	kPa		36	50	67
Maximum Working Pressure (Cooling)	kPa		1,608		
Surface Air Velocity	m/s		1.5	1.63	1.5
Sound Pressure Level (H/M/L)	dBA		48 / 47 / 44	52 / 47 / 46	52 / 50 / 49
Unit Dimension	Height	mm (in)	259 (10)		
	Width	mm (in)	1,320 (52)	1,538 (61)	1,786 (70)
	Depth	mm (in)	635 (25)		
Packing Dimension	Height	mm (in)	348 (14)		
	Width	mm (in)	1,393 (55)	1,612 (63)	1,860 (73)
	Depth	mm (in)	734 (29)		
Unit Weight	kg (lb)		41 (90)	46 (101)	53 (117)
Condensate Drain Pipe Size	mm (in)		19.05 (3/4)		
Pipe Connection	Type		BSP FEMALE THREAD ADAPTOR		
	Size	mm (in)	19.05 (3/4)		
Filter	Type		WASHABLE SARANET FILTER		
	Quantity	pcs	3	3	4
Casing	Colour		LIGHT GREY		

Notes:

1. Nominal cooling capacity are based on the conditions below:

Mode	Cooling
Entering Air Temperature	27°C DB / 19°C WB
Entering Water Temperature	7°C
Leaving Water Temperature	12°C

2. Sound measurement position is 1m in front of the unit and 0.8m up to 1m below the air discharge opening.

3. All specifications are subjected to change by the manufacturer without prior notice.

Specifications

ACC 10CW - ACC 60CW (Ceiling Concealed - Medium Static)

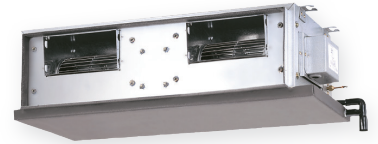

Model		ACC 10CW	ACC 15CW	ACC 20CW	ACC 25CW	ACC 30CW	ACC 40CW	ACC 50CW	ACC 60CW	
Nominal Cooling Capacity (High)	BTU/h	9,900	11,600	18,000	22,500	24,800	37,000	44,700	51,800	
	kW	2.90	3.40	5.28	6.59	7.27	10.84	13.10	15.18	
Nominal Cooling Capacity (Medium)	BTU/h	9,800	11,500	17,600	21,000	23,300	35,800	43,600	50,500	
	kW	2.87	3.37	5.16	6.15	6.83	10.49	12.78	14.80	
Nominal Cooling Capacity (Low)	BTU/h	8,600	10,100	17,000	19,300	22,200	33,900	42,800	47,900	
	kW	2.52	2.96	4.98	5.66	6.51	9.94	12.54	14.04	
Nominal Total Input Power		kW	0.089	0.14	0.168	0.182	0.345	0.442	0.427	0.531
Nominal Operating Current		A	0.4	0.65	0.77	0.86	1.5	1.93	1.86	2.32
Power Source		V/Ph/Hz	220 ~ 240 / 1 / 50							
Control	Air Discharge	HORIZONTAL - DUCTED								
	Operation (Optional)	WIRED (WIRELESS)								
Air Flow Rate	High	l/s (CFM)	142 (300)	241 (510)	330 (700)	345 (730)	392 (830)	585 (1,240)	632 (1,340)	732 (1,550)
	Medium	l/s (CFM)	135 (285)	231 (490)	319 (675)	311 (660)	359 (760)	519 (1,100)	576 (1,220)	661 (1,400)
	Low	l/s (CFM)	123 (260)	189 (400)	302 (640)	274 (580)	335 (710)	481 (1,020)	562 (1,190)	614 (1,300)
External Static Pressure With Filter	Pa	49 / 44 / 36	49 / 42 / 28	49 / 45 / 41	49 / 43 / 30	167 / 128 / 88	128 / 88 / 39	157 / 137 / 108	157 / 137 / 98	
	in.wg	0.2 / 0.18 / 0.14	0.2 / 0.17 / 0.11	0.2 / 0.18 / 0.16	0.2 / 0.17 / 0.12	0.67 / 0.51 / 0.35	0.51 / 0.35 / 0.16	0.63 / 0.55 / 0.43	0.63 / 0.55 / 0.39	
Nominal Water Flow Rate	USGPM	2.2	2.6	4.05	5.06	5.55	8.28	10.04	11.62	
	liters/min	8.33	9.84	15.33	19.15	21.01	31.34	38.0	43.98	
Head Loss (Cooling)	kPa	10.5	24	20.1	32.4	14	23	38	51	
Maximum Working Pressure (Cooling)	kPa	1,608								
Surface Air Velocity	m/s	1.23	1.68	1.88	1.7	1.41	1.83	1.54	1.52	
Sound Pressure Level (H/M/L)	dBA	36 / 35 / 33	40 / 38 / 33	42 / 41 / 40	41 / 40 / 36	46 / 42 / 38	49 / 45 / 41	52 / 50 / 47	53 / 50 / 47	
Unit Dimension	Height	mm (in)	267 (11)				384 (15)			
	Width	mm (in)	702 (28)	842 (33)	1,002 (39)	1,137 (45)	917 (36)	1,003 (39)	1,287 (51)	1,487 (59)
	Depth	mm (in)	351 (14)				462 (18)			
Packing Dimension	Height	mm (in)	376 (15)				415 (16)			
	Width	mm (in)	951 (37)	1,091 (43)	1,251 (49)	1,386 (55)	1,126 (44)	1,245 (49)	1,497 (59)	1,701 (67)
	Depth	mm (in)	541 (21)				631 (25)			
Unit Weight	kg (lb)	18 (40)	22 (49)	24 (53)	26 (57)	42 (93)	44 (97)	50 (110)	56 (123)	
Condensate Drain Pipe Size	mm (in)	19.05 (3/4)								
Pipe Connection	Type	BSP FEMALE THREAD ADAPTOR								
	Size	mm (in)	19.05 (3/4)							
Filter	Type	WASHABLE SARANET FILTER								
	Quantity	pcs	1							
Casing	Colour	WITHOUT PAINT								

Notes:

1. Nominal cooling capacity are based on the conditions below:

Mode	Cooling
Entering Air Temperature	27°C DB / 19°C WB
Entering Water Temperature	7°C
Leaving Water Temperature	12°C

2. Sound measurement position is 1.5m below the centre of the unit with 2m length duct at the air discharge outlet and air return inlet.

3. All specifications are subjected to change by the manufacturer without prior notice.

Specifications

ACSC 10CW - ACSC 60CW (Double Skin Ceiling Concealed)



Model			ACSC 10CW	ACSC 15CW	ACSC 20CW	ACSC 25CW	ACSC 30CW	ACSC 40CW	ACSC 50CW	ACSC 60CW	
Nominal Cooling Capacity (High)	BTU/h		9,900	11,600	18,000	22,500	24,800	37,000	44,700	51,800	
	kW		2.90	3.40	5.28	6.59	7.27	10.84	13.10	15.18	
Nominal Cooling Capacity (Medium)	BTU/h		9,800	11,500	17,600	21,000	23,300	35,800	43,600	50,500	
	kW		2.87	3.37	5.16	6.15	6.83	10.49	12.78	14.80	
Nominal Cooling Capacity (Low)	BTU/h		8,600	10,100	17,000	19,300	22,200	33,900	42,800	47,900	
	kW		2.52	2.96	4.98	5.66	6.51	9.94	12.54	14.04	
Nominal Total Input Power	kW		0.089	0.14	0.168	0.182	0.345	0.442	0.427	0.531	
Nominal Operating Current	A		0.4	0.65	0.77	0.86	1.5	1.93	1.86	2.32	
Power Source	V/Ph/Hz		220 ~ 240 / 1 / 50								
Control	Air Discharge		HORIZONTAL - DUCTED								
	Operation (Optional)		WIRED (WIRELESS)								
Air Flow Rate	High	l/s (CFM)	142 (300)	241 (510)	330 (700)	345 (730)	392 (830)	585 (1,240)	632 (1,340)	732 (1,550)	
	Medium	l/s (CFM)	135 (285)	231 (490)	319 (675)	311 (660)	359 (760)	519 (1,100)	576 (1,220)	661 (1,400)	
	Low	l/s (CFM)	123 (260)	189 (400)	302 (640)	274 (580)	335 (710)	481 (1,020)	562 (1,190)	614 (1,300)	
External Static Pressure With Filter	Pa		49 / 44 / 36	49 / 42 / 28	49 / 45 / 41	49 / 43 / 30	167 / 128 / 88	128 / 88 / 39	157 / 137 / 108	157 / 137 / 98	
	in.wg		0.2 / 0.18 / 0.14	0.2 / 0.17 / 0.11	0.2 / 0.18 / 0.16	0.2 / 0.17 / 0.12	0.67 / 0.51 / 0.35	0.51 / 0.35 / 0.16	0.63 / 0.55 / 0.43	0.63 / 0.55 / 0.39	
Nominal Water Flow Rate	USGPM		2.2	2.6	4.05	5.06	5.55	8.28	10.04	11.62	
	liters/min		8.33	9.84	15.33	19.15	21.01	31.34	38	43.98	
Head Loss (Cooling)	kPa		10.5	24	20.1	32.4	14	23	38	51	
Maximum Working Pressure (Cooling)	kPa		1,608								
Surface Air Velocity	m/s		1.23	1.68	1.88	1.7	1.41	1.83	1.54	1.52	
Sound Pressure Level (H/M/L)	dBA		33 / 32 / 30	37 / 35 / 30	40 / 38 / 37	40 / 38 / 35	45 / 41 / 37	48 / 44 / 40	50 / 48 / 45	52 / 49 / 45	
Unit Dimension	Height	mm (in)	330 (13)				480 (19)				
	Width	mm (in)	760 (30)	900 (35)	1,060 (42)	1,195 (47)	975 (38)	1,090 (43)	1,345 (53)	1,545 (61)	
	Depth	mm (in)	510 (20)				620 (24)				
Packing Dimension	Height	mm (in)	454 (18)				604 (24)				
	Width	mm (in)	810 (32)	950 (37)	1,110 (44)	1,245 (49)	1,025 (40)	1,140 (45)	1,395 (55)	1,596 (63)	
	Depth	mm (in)	674 (27)				784 (31)				
Unit Weight	kg (lb)		25 (55)	29 (64)	32 (71)	35 (77)	52 (115)	54 (119)	62 (137)	69 (152)	
Condensate Drain Pipe Size	mm (in)		19.05 (3/4)								
Pipe Connection	Type		BSP FEMALE THREAD ADAPTOR								
	Size	mm (in)	19.05 (3/4)								
Filter	Type		WASHABLE SARANET FILTER								
	Quantity	pcs	1								
Casing	Colour		WITHOUT PAINT								

Notes:

1. Nominal cooling capacity are based on the conditions below:

Mode	Cooling
Entering Air Temperature	27°C DB / 19°C WB
Entering Water Temperature	7°C
Leaving Water Temperature	12°C

2. Sound measurement position is 1.5m below the centre of the unit with 2m length duct at the air discharge outlet and air return inlet.

3. All specifications are subjected to change by the manufacturer without prior notice.

Specifications

ACC 02GW - ACC 12GW (Ceiling Concealed - Low Static Pressure)

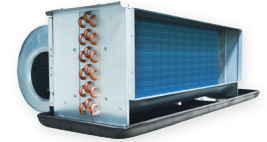

Model		ACC 02GW	ACC 03GW	ACC 04GW	ACC 06GW	ACC 08GW	ACC 10GW	ACC 12GW	
Nominal Cooling Capacity (High)	BTU/h	6,000	9,000	12,000	18,000	24,000	30,000	36,000	
	kW	1.76	2.64	3.52	5.28	7.03	8.79	10.55	
Nominal Cooling Capacity (Medium)	BTU/h	5,000	6,900	10,200	16,400	21,000	26,700	32,800	
	kW	1.47	2.02	2.99	4.81	6.15	7.83	9.61	
Nominal Cooling Capacity (Low)	BTU/h	4,400	5,200	7,000	13,700	17,000	22,100	29,100	
	kW	1.29	1.52	2.05	4.02	4.98	6.48	8.53	
Nominal Total Input Power	kW	0.053	0.061	0.081	0.116	0.159	0.202	0.241	
Nominal Operating Current	A	0.23	0.27	0.36	0.5	0.72	0.9	1.05	
Power Source	V/Ph/Hz	220 ~ 240 / 1 / 50							
Control	Air Discharge	DUCTED							
	Operation	WITHOUT CONTROLLER							
Air Flow Rate	High	l/s (CFM)	94 (200)	142 (300)	189 (400)	283 (600)	378 (800)	472 (1,000)	566 (1,200)
	Medium	l/s (CFM)	76 (160)	104 (220)	144 (305)	236 (500)	307 (650)	380 (805)	460 (975)
	Low	l/s (CFM)	61 (130)	71 (150)	94 (200)	182 (385)	219 (465)	283 (600)	382 (810)
External Static Pressure With Filter	Pa	30 / 19 / 12	30 / 16 / 7	30 / 18 / 7	30 / 21 / 13	30 / 19 / 10	30 / 18 / 11	30 / 20 / 13	
	in.wg	0.12 / 0.08 / 0.05	0.12 / 0.06 / 0.03	0.12 / 0.07 / 0.03	0.12 / 0.08 / 0.05	0.12 / 0.08 / 0.04	0.12 / 0.07 / 0.04	0.12 / 0.08 / 0.05	
Nominal Water Flow Rate	USGPM	1.32	2	2.66	3.99	5.33	6.66	7.99	
	liters/min	5	7.57	10.09	15.13	20.18	25.22	30.26	
Head Loss (Cooling)	kPa	8.5	20	25	34	38	42	38	
Maximum Working Pressure (Cooling)	kPa	1608							
Surface Air Velocity	m/s	1.26	1.17	1.56	1.99	1.69	2.11	2.05	
Sound Pressure Level (H/M/L)	dBA	31 / 26 / 20	32 / 25 / 20	35 / 29 / 21	38 / 35 / 30	39 / 34 / 26	41 / 37 / 31	42 / 39 / 35	
Unit Dimension	Height	mm (in)	251 (10)						
	Width	mm (in)	630 (25)	774 (30)		874 (34)	1,264 (50)		1,514 (60)
	Depth	mm (in)	461 (18)						
Packing Dimension	Height	mm (in)	595 (23)						
	Width	mm (in)	836 (33)	984 (39)		1,084 (43)	1,473 (58)		1,724 (68)
	Depth	mm (in)	284 (11)						
Unit Weight	kg (lb)	11 (24)	14.5 (32)	15 (33)	17.5 (39)	26 (57)	26 (57)	30 (66)	
Condensate Drain Pipe Size	mm (in)	19.05 (3/4)							
Pipe Connection	Type	BSP FEMALE THREAD ADAPTOR							
	Size	mm (in)	19.05 (3/4)						
Filter	Type	WASHABLE SARANET FILTER							
	Quantity	pcs	2						
Casing	Colour	WITHOUT PAINT							

Notes:

1. Nominal cooling capacity are based on the conditions below:

Mode	Cooling
Entering Air Temperature	27°C DB / 19°C WB
Entering Water Temperature	7°C
Leaving Water Temperature	12°C

2. Sound measurement position is 1.5m below the centre of the unit with 2m length duct at the air discharge outlet and 1m length of duct at the air return inlet.
3. All specifications are subjected to change by the manufacturer without prior notice.

Specifications

ACC 03GW - ACC 20GW (Ceiling Concealed - Medium Static Pressure)

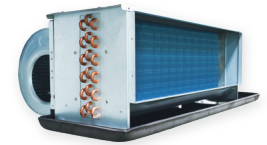

Model			ACC 03GW	ACC 04GW	ACC 06GW	ACC 08GW	ACC 10GW	ACC 12GW	ACC 14GW	ACC 16GW	ACC 18GW	ACC 20GW	
Nominal Cooling Capacity (High)	BTU/h		9,000	12,000	18,000	24,000	30,000	36,000	42,000	48,000	54,000	60,000	
	kW		2.64	3.52	5.28	7.03	8.79	10.55	12.31	14.07	15.83	17.58	
Nominal Cooling Capacity (Medium)	BTU/h		6,900	10,200	16,400	21,000	26,700	32,800	36,700	41,200	47,200	52,700	
	kW		2.02	2.99	4.81	6.15	7.83	9.61	10.76	12.08	13.83	15.45	
Nominal Cooling Capacity (Low)	BTU/h		5,200	7,000	13,700	17,000	22,100	29,100	29,100	31,700	38,300	41,100	
	kW		1.52	2.05	4.02	4.98	6.48	8.53	8.53	9.29	11.23	12.05	
Nominal Total Input Power	kW		0.061	0.087	0.13	0.184	0.235	0.246	0.45	0.558	0.624	0.659	
Nominal Operating Current	A		0.27	0.38	0.58	0.81	1.03	1.1	1.96	2.43	2.72	2.87	
Power Source	V/Ph/Hz		220 ~ 240 / 1 / 50										
Control	Air Discharge		DUCTED										
	Operation		WITHOUT CONTROLLER										
Air Flow Rate	High	l/s (CFM)	142 (300)	189 (400)	283 (600)	378 (800)	472 (1,000)	566 (1,200)	661 (1,400)	755 (1,600)	850 (1,800)	944 (2,000)	
	Medium	l/s (CFM)	104 (220)	144 (305)	236 (500)	307 (650)	380 (805)	460 (975)	533 (1,130)	614 (1,300)	682 (1,445)	722 (1,530)	
	Low	l/s (CFM)	71 (150)	94 (200)	182 (385)	219 (465)	283 (600)	382 (810)	389 (825)	427 (905)	500 (1,060)	507 (1,075)	
External Static Pressure With Filter	Pa		50 / 32 / 15	50 / 32 / 15	50 / 35 / 20	50 / 33 / 17	50 / 33 / 18	50 / 33 / 23	75 / 48 / 24	75 / 48 / 24	75 / 48 / 25	75 / 45 / 22	
	in.wg		0.2 / 0.13 / 0.06	0.2 / 0.13 / 0.06	0.2 / 0.14 / 0.08	0.2 / 0.13 / 0.07	0.2 / 0.13 / 0.07	0.2 / 0.13 / 0.09	0.3 / 0.19 / 0.1	0.3 / 0.19 / 0.1	0.3 / 0.19 / 0.1	0.3 / 0.18 / 0.09	
Nominal Water Flow Rate	USGPM		2	2.66	3.99	5.33	6.66	7.99	9.32	10.65	11.98	13.31	
	liters/min		7.57	10.09	15.13	20.18	25.22	30.26	35.31	40.35	45.4	50.44	
Head Loss (Cooling)	kPa		20	25	34	38	42	38	31	27	33	32	
Maximum Working Pressure (Cooling)	kPa		1608										
Surface Air Velocity	m/s		1.17	1.56	1.99	1.69	2.11	2.05	2.43	2.41	2.71	2.65	
Sound Pressure Level (H/M/L)	dBA		35 / 29 / 20	37 / 31 / 22	41 / 37 / 31	43 / 37 / 30	44 / 40 / 33	44 / 40 / 37	47 / 43 / 35	48 / 44 / 37	49 / 45 / 39	50 / 46 / 38	
Unit Dimension	Height	mm (in)	251 (10)						363 (14)				
	Width	mm (in)	774 (30)		874 (34)		1,264 (50)		1,514 (60)	1,116 (44)	1,254 (49)		1,394 (55)
	Depth	mm (in)	461 (18)						660 (26)				
Packing Dimension	Height	mm (in)	595 (23)						760 (30)				
	Width	mm (in)	984 (39)		1,084 (43)		1,473 (58)		1,724 (68)	1,331 (52)	1,469 (58)		1,609 (63)
	Depth	mm (in)	284 (11)						395 (16)				
Unit Weight	kg (lb)	14.5 (32)	15 (33)	17.5 (39)	26 (57)		30 (66)	34 (75)	37 (82)	38 (84)	41 (90)		
Condensate Drain Pipe Size	mm (in)	19.05 (3/4)											
Pipe Connection	Type		BSP FEMALE THREAD ADAPTOR										
	Size	mm (in)	19.05 (3/4)						25.4 (1)				
Filter	Type		WASHABLE SARANET FILTER										
	Quantity	pcs	2	2	2	3	3	4	2	3	3	3	
Casing	Colour		WITHOUT PAINT										

Notes:

1. Nominal cooling capacity are based on the conditions below:

Mode	Cooling
Entering Air Temperature	27°C DB / 19°C WB
Entering Water Temperature	7°C
Leaving Water Temperature	12°C

2. Sound measurement position is 1.5m below the centre of the unit with 2m length duct at the air discharge outlet and 1m length of duct at the air return inlet.
3. All specifications are subjected to change by the manufacturer without prior notice.

Specifications

ACC08VW - ACC20VW (Ceiling Concealed - Low Static Pressure)



Model			ACC08VW	ACC12VW	ACC15VW	ACC18VW	ACC20VW	
Nominal Cooling Capacity		BTU/h	7,575	11,260	14,536	17,231	19,859	
		kW	2.22	3.30	4.26	5.05	5.82	
Nominal Total Input Power	12 Pa (H/M/L)	kW	32 / 29 / 22	43 / 37 / 28	56 / 49 / 37	73 / 64 / 46	93 / 81 / 66	
	30 Pa (H/M/L)	kW	39 / 36 / 27	53 / 45 / 34	70 / 58 / 46	84 / 73 / 55	102 / 93 / 75	
	50 Pa (H/M/L)	kW	46 / 39 / 29	62 / 52 / 43	80 / 75 / 68	95 / 86 / 70	114 / 107 / 91	
Nominal Total Input Power (equipped with DC motor - optional)	12 Pa (H/M/L)	kW	15 / 9 / 5	19 / 11 / 5	33 / 19 / 8	40 / 23 / 9	54 / 30 / 11	
	30 Pa (H/M/L)	kW	21 / 12 / 6	26 / 15 / 7	40 / 24 / 9	51 / 29 / 10	65 / 38 / 12	
	50 Pa (H/M/L)	kW	26 / 16 / 7	36 / 20 / 8	49 / 29 / 11	61 / 36 / 12	80 / 47 / 14	
Nominal Operating Current	12 Pa (H/M/L)	A	0.15 / 0.14 / 0.11	0.2 / 0.17 / 0.13	0.26 / 0.23 / 0.17	0.34 / 0.3 / 0.22	0.43 / 0.38 / 0.31	
	30 Pa (H/M/L)	A	0.18 / 0.17 / 0.13	0.24 / 0.21 / 0.16	0.33 / 0.27 / 0.22	0.38 / 0.34 / 0.26	0.49 / 0.43 / 0.35	
	50 Pa (H/M/L)	A	0.21 / 0.18 / 0.14	0.28 / 0.24 / 0.2	0.37 / 0.35 / 0.32	0.44 / 0.4 / 0.33	0.51 / 0.5 / 0.42	
Nominal Operating Current (equipped with DC motor - optional)	12 Pa (H/M/L)	A	0.14 / 0.11 / 0.07	0.17 / 0.12 / 0.07	0.27 / 0.18 / 0.1	0.33 / 0.22 / 0.1	0.42 / 0.27 / 0.11	
	30 Pa (H/M/L)	A	0.19 / 0.13 / 0.08	0.23 / 0.15 / 0.08	0.33 / 0.22 / 0.11	0.41 / 0.26 / 0.11	0.52 / 0.33 / 0.13	
	50 Pa (H/M/L)	A	0.23 / 0.16 / 0.08	0.3 / 0.19 / 0.09	0.41 / 0.26 / 0.12	0.5 / 0.32 / 0.12	0.64 / 0.4 / 0.14	
Power Source	V/Ph/Hz	220 ~ 240 / 1 / 50						
Control	Air Discharge	DUCTED						
	Operation	WITHOUT CONTROLLER						
Air Flow Rate	High	l/s (CFM)	94 (200)	142 (300)	189 (400)	236 (500)	283 (600)	
	Medium	l/s (CFM)	78 (164)	116 (246)	147 (312)	178 (376)	219 (465)	
	Low	l/s (CFM)	47 (100)	71 (150)	94 (200)	118 (250)	142 (300)	
External Static Pressure With Filter	Pa (in wg)	12, 30, 50 (0.05, 0.12, 0.20)						
Nominal Water Flow Rate	USGPM		1.67	2.51	3.21	3.83	4.4	
	litres/min		6.32	9.50	12.15	14.50	16.66	
Head Loss (Cooling)	kPa		25	21	30	30	32	
Maximum Working Pressure (Cooling)	MPa		1.6					
Surface Air Velocity	m/s		1.18	1.18	1.45	1.57	1.66	
Sound Pressure Level	12 Pa (H/M/L)	dB(A)	35 / 30 / 21	36 / 29.5 / 25	40.5 / 36 / 25	41 / 37 / 26	45 / 39.5 / 30	
	30 Pa (H/M/L)	dB(A)	35 / 30.5 / 19.5	36.5 / 30.5 / 19.5	39 / 32.5 / 21.5	41 / 36.5 / 26.5	43.5 / 38 / 27.5	
	50 Pa (H/M/L)	dB(A)	39 / 33.5 / 21.5	40 / 34.5 / 23	42 / 40 / 27	43.5 / 41.5 / 31	45.5 / 39 / 28	
Sound Pressure Level (equipped with DC motor- optional)	12 Pa (H/M/L)	dB(A)	34 / 29 / 20.5	35 / 30 / 20.5	38.5 / 33 / 23	42 / 37 / 25.5	44 / 38.5 / 27	
	30 Pa (H/M/L)	dB(A)	34 / 29.5 / 20	36 / 29 / 20.5	38.5 / 32.5 / 21.5	41 / 35 / 24.5	42 / 38 / 26.5	
	50 Pa (H/M/L)	dB(A)	38.5 / 33.5 / 23.5	39 / 33.5 / 23.5	41 / 36 / 23.5	43 / 37.5 / 25.5	45 / 40.5 / 29	
Unit Dimension (without plenum)	Height	mm (in)	250 (9.8)					
	Width	mm (in)	641 (25)	831 (33)	881 (35)	961 (38)	1061 (42)	
	Depth	mm (in)	520 (20)					
Unit Weight (w/o plenum)	kg/lb		9.2 / 20.3	12.2 / 26.9	12.6 / 27.8	14.5 / 32.0	15.3 / 33.7	
Gross Weight (w/o plenum)	kg/lb		11.3 / 24.9	14.5 / 32.0	15.1 / 33.3	17.2 / 38.0	18 / 39.7	
Unit Weight (w/o plenum)	(equipped with DC motor - optional)	kg/lb	11 / 24.3	13.6 / 30	14 / 30.9	15 / 33.1	15.9 / 35.1	
Gross Weight (w/o plenum)		kg/lb	12.9 / 28.4	15.9 / 35.1	16.4 / 36.2	17.6 / 38.8	18.7 / 41.2	
Condensate Drain Pipe Size	mm (in)	19.05 (3/4)						
Pipe Connection	Type	BSP FEMALE THREAD ADAPTOR						
	Size	mm (in)	19.05 (3/4)					
Filter	Type	NYLON FILTER						
	Quantity	pcs	1					
Casing	Colour	WITHOUT PAINT						

Notes:

1. Nominal cooling capacity are based on the conditions below:

Mode	Cooling
Entering Air Temperature	27°C DB/ 19.5°C WB
Entering Water Temperature	7°C
Leaving Water Temperature	12°C

2. Sound pressure measured at 1m in front of the unit and 1m below the vertical center line of the unit and tested in semi anechoic room with background sound pressure level at 11.5dB(A).

3. Sound pressure level measured in semi-anechoic room with background 11.5 dB(A).
12Pa unit: 1 meter front and 1 meter below the unit, with return air duct; 30/50Pa unit: 1 meter below the unit, with return and supply air duct."

4. ACC-VW series can be equipped with DC motor.

5. All specifications are subjected to change by the manufacturer without prior notice.

Specifications

ACC25VW - ACC45VW (Ceiling Concealed - Low Static Pressure)



Model			ACC25VW	ACC30VW	ACC35VW	ACC40VW	ACC45VW	
Nominal Cooling Capacity		BTU/h	22,520	27,980	31,733	38,182	44,358	
		kW	6.60	8.20	9.30	11.19	13.00	
Nominal Total Input Power	12 Pa (H/M/L)	kW	112 / 100 / 80	130 / 116 / 92	147 / 134 / 114	183 / 159 / 127	221 / 209 / 173	
	30 Pa (H/M/L)	kW	118 / 108 / 88	142 / 132 / 105	169 / 160 / 141	206 / 204 / 164	245 / 226 / 193	
	50 Pa (H/M/L)	kW	131 / 111 / 99	168 / 146 / 118	200 / 191 / 171	237 / 216 / 195	291 / 280 / 256	
Nominal Total Input Power (equipped with DC motor - optional)	12 Pa (H/M/L)	kW	67 / 42 / 15	65 / 38 / 15	88 / 57 / 20	114 / 68 / 23	139 / 88 / 29	
	30 Pa (H/M/L)	kW	73 / 48 / 17	80 / 49 / 17	101 / 68 / 23	140 / 83 / 27	166 / 103 / 32	
	50 Pa (H/M/L)	kW	90 / 57 / 20	101 / 59 / 19	125 / 80 / 26	173 / 99 / 31	208 / 121 / 37	
Nominal Operating Current	12 Pa (H/M/L)	A	0.52 / 0.46 / 0.37	0.61 / 0.54 / 0.43	0.7 / 0.68 / 0.55	0.86 / 0.74 / 0.59	1.12 / 0.96 / 0.8	
	30 Pa (H/M/L)	A	0.56 / 0.5 / 0.41	0.65 / 0.61 / 0.49	0.8 / 0.77 / 0.65	1 / 0.94 / 0.76	1.19 / 1.04 / 0.89	
	50 Pa (H/M/L)	A	0.6 / 0.51 / 0.46	0.77 / 0.68 / 0.55	0.92 / 0.88 / 0.79	1.09 / 1 / 0.9	1.45 / 1.29 / 1.18	
Nominal Operating Current (equipped with DC motor - optional)	12 Pa (H/M/L)	A	0.54 / 0.36 / 0.15	0.54 / 0.35 / 0.16	0.81 / 0.5 / 0.2	0.91 / 0.58 / 0.24	1.13 / 0.76 / 0.28	
	30 Pa (H/M/L)	A	0.62 / 0.4 / 0.17	0.68 / 0.42 / 0.18	0.94 / 0.58 / 0.22	1.08 / 0.69 / 0.27	1.34 / 0.88 / 0.31	
	50 Pa (H/M/L)	A	0.73 / 0.47 / 0.19	0.83 / 0.5 / 0.19	1.11 / 0.67 / 0.25	1.31 / 0.8 / 0.3	1.6 / 1.01 / 0.35	
Power Source	V/Ph/Hz	220 ~ 240 / 1 / 50						
Control	Air Discharge	DUCTED						
	Operation	WITHOUT CONTROLLER						
Air Flow Rate	High	l/s (CFM)	325 (688)	378(800)	472 (1000)	567 (1200)	661 (1400)	
	Medium	l/s (CFM)	250 (529)	310 (656)	375(794)	444 (941)	542 (1148)	
	Low	l/s (CFM)	163 (344)	189 (400)	236 (500)	283 (600)	331 (700)	
External Static Pressure With Filter	Pa (in wg)	12, 30, 50 (0.05, 0.12, 0.20)						
Nominal Water Flow Rate	USGPM	4.98	6.2	7	8.45	9.82		
	litres/min	18.85	23.47	26.50	31.99	37.17		
Head Loss (Cooling)	kPa	35	32	40	35	50		
Maximum Working Pressure (Cooling)	MPa	1.6						
Surface Air Velocity	m/s	1.81	1.51	1.82	1.89	1.94		
Sound Pressure Level	12 Pa (H/M/L)	dB(A)	45.5 / 41 / 30	44.5 / 39 / 29	48 / 44 / 33	49 / 45 / 34	51 / 47.5 / 38	
	30 Pa (H/M/L)	dB(A)	44.5 / 41.5 / 30	43.5 / 36.5 / 25.5	46.5 / 41.5 / 30.5	47.5 / 39.5 / 31.5	49.5 / 42.5 / 32.5	
	50 Pa (H/M/L)	dB(A)	45.5 / 43 / 38	45.5 / 40 / 27.5	48 / 45 / 36.5	49 / 43.5 / 37.5	50.5 / 46 / 38.5	
Sound Pressure Level (equipped with DC motor- optional)	12 Pa (H/M/L)	dB(A)	45.5 / 41 / 28	44.5 / 40 / 28.5	47 / 41.5 / 29	48.5 / 44 / 32	50.5 / 45.5 / 34	
	30 Pa (H/M/L)	dB(A)	43 / 40 / 29	43 / 36.5 / 25.5	45.5 / 40 / 28.5	46 / 39.5 / 28.5	48.5 / 43 / 30.5	
	50 Pa (H/M/L)	dB(A)	45 / 41 / 31	45.5 / 40 / 27.5	47 / 42 / 30.5	48 / 42 / 30	50.5 / 45 / 33	
Unit Dimension (without plenum)	Height	mm (in)	250 (9.8)					
	Width	mm (in)	1111 (44)	1441(57)	1491 (59)	1691 (67)	1841 (72)	
	Depth	mm (in)	520 (20)					
Unit Weight (w/o plenum)	kg/lb	16.7 / 36.8	24.5 / 54.0	25.9 / 57.1	29.4 / 64.8	32.6 / 71.9		
Gross Weight (w/o plenum)	kg/lb	19.5 / 43.0	28.2 / 62.2	29.7 / 65.5	33.8 / 74.5	37.6 / 82.9		
Unit Weight (w/o plenum)	(equipped with DC motor - optional)	kg/lb	16.5 / 36.4	25.5 / 56.2	26.2 / 57.8	29.5 / 65.0	31.6 / 69.7	
Gross Weight (w/o plenum)		kg/lb	19.2 / 42.3	29.1 / 64.2	29.8 / 65.7	33.4 / 73.6	36 / 79.4	
Condensate Drain Pipe Size	mm (in)	19.05 (3/4)						
Pipe Connection	Type	BSP FEMALE THREAD ADAPTOR						
	Size	mm (in)	19.05 (3/4)					
Filter	Type	NYLON FILTER						
	Quantity	pcs	1					
Casing	Colour	WITHOUT PAINT						

Notes:

1. Nominal cooling capacity are based on the conditions below:

Mode	Cooling
Entering Air Temperature	27°C DB/ 19.5°C WB
Entering Water Temperature	7°C
Leaving Water Temperature	12°C

2. Sound pressure measured at 1m in front of the unit and 1m below the vertical center line of the unit and tested in semi anechoic room with background sound pressure level at 11.5dB(A).

3. Sound pressure level measured in semi-anechoic room with background 11.5 dB(A).
12Pa unit: 1 meter front and 1 meter below the unit, with return air duct; 30/50Pa unit: 1 meter below the unit, with return and supply air duct."

4. ACC-VW series can be equipped with DC motor.

5. All specifications are subjected to change by the manufacturer without prior notice.

Specifications

ACC 06FWD - ACC 30FWD (Ceiling Concealed)



Model			ACC 06FWD	ACC 09FWD	ACC 12FWD	ACC 15FWD	ACC 18FWD	ACC 24FWD	ACC 30FWD
Nominal Cooling Capacity	BTU/h		6,600	8,700	12,100	14,000	17,000	24,500	28,500
	kW		1.93	2.55	3.55	4.10	4.98	7.18	8.35
Nominal Total Input Power	kW		0.092	0.108	0.131	0.151	0.192	0.265	0.321
Nominal Operating Current	A		0.42	0.5	0.58	0.66	0.95	1.28	1.57
Power Source	V/Ph/Hz		220 ~ 240 / 1 / 50						
Control	Air Discharge		DUCTED						
	Operation		WITHOUT CONTROLLER						
Air Flow Rate	High	l/s (CFM)	132 (280)	146 (310)	212 (450)	217 (460)	269 (570)	387 (820)	444 (940)
	Medium	l/s (CFM)	127 (270)	142 (300)	203 (430)	212 (450)	264 (560)	378 (800)	434 (920)
	Low	l/s (CFM)	104 (220)	132 (280)	170 (360)	189 (400)	236 (500)	354 (750)	396 (840)
External Static Pressure With Filter	Pa (in.wg)		53 / 50 / 34 (0.21 / 0.2 / 0.14)	53 / 50 / 44 (0.21 / 0.2 / 0.18)	55 / 50 / 40 (0.22 / 0.2 / 0.16)	78 / 75 / 60 (0.31 / 0.3 / 0.24)	77 / 75 / 61 (0.31 / 0.3 / 0.24)	78 / 75 / 66 (0.31 / 0.3 / 0.26)	78 / 75 / 67 (0.31 / 0.3 / 0.27)
Nominal Water Flow Rate	USGPM		0.84	1.06	1.5	1.72	2.11	3.04	3.52
	liters/min		3.17	4	5.67	6.5	8	11.5	13.33
Head Loss (Cooling)	kPa		24.9	20.8	17.2	31.2	18.7	25.0	19.4
Maximum Working Pressure (Cooling)	kPa		1,608						
Surface Air Velocity	m/s		1.2	1.33	1.25	1.28	1.24	1.29	1.22
Sound Pressure Level (H/M/L)	dBA		40 / 39 / 36	40 / 39 / 37	41 / 40 / 37	42 / 41 / 39	45 / 44 / 41	47 / 46 / 45	48 / 47 / 45
Unit Dimension	Height	mm (in)	247 (10)						
	Width	mm (in)	619 (24)		870 (34)		1,060 (42)	1,390 (55)	1,600 (63)
	Depth	mm (in)	552 (22)						
Packing Dimension	Height	mm (in)	320 (13)						
	Width	mm (in)	737 (29)		987 (39)		1,177 (46)	1,507 (59)	1,717 (68)
	Depth	mm (in)	630 (25)						
Unit Weight	kg (lb)		16 (35)	17 (37)	23 (51)	24 (53)	28 (62)	38 (84)	45 (99)
Condensate Drain Pipe Size	mm (in)		19.05 (3/4)						
Pipe Connection	Type		BSP FEMALE THREAD ADAPTOR						
	Size	mm (in)	19.05 (3/4)						
Filter	Type		WASHABLE SARANET FILTER						
	Quantity	pcs	2					3	
Casing	Colour		WITHOUT PAINT						

Notes:

1. Nominal cooling capacity are based on the conditions below:

Mode	Cooling
Entering Air Temperature	24°C DB / 18°C WB
Entering Water Temperature	5.5°C
Leaving Water Temperature	14.5°C

- Sound measurement position is 1.5m below the centre of the unit with 2m length duct at the air discharge outlet and 1m length of duct at the air return inlet.
- All specifications are subjected to change by the manufacturer without prior notice.

Specifications

ADB 75BW - ADB 150BW (Ducted Blower)



Model			ADB 75BW	ADB 100BW	ADB 125BW	ADB 150BW
Nominal Cooling Capacity	BTU/h		75,600	95,000	125,000	150,000
	kW		22.16	27.84	36.64	43.96
Nominal Total Input Power	kW		0.76	1.8	1.62	1.91
Nominal Operating Current	A		3.49	7.84	3.33	4.03
Power Source	V/Ph/Hz		220 ~ 240 / 1 / 50		380 ~ 415 / 3 / 50	
Control	Air Discharge		DUCTED			
	Operation		WITHOUT CONTROLLER			
Air Flow Rate	High	l/s (CFM)	1,180 (2,500)	1,510 (3,200)	1,982 (4,200)	2,171 (4,600)
	Medium	l/s (CFM)	991 (2,100)	1,416 (3,000)	N/A	N/A
	Low	l/s (CFM)	826 (1,750)	1,321 (2,800)	N/A	N/A
External Static Pressure With Filter	Pa (in.wg)		100 / 72 / 50	100 / 80 / 60	149*	149*
Nominal Water Flow Rate	USGPM		16.9	21.1	27.7	33.3
	liters/min		64	80	105	126
Head Loss (Cooling)	kPa		34.5	42	48.8	53.3
Maximum Working Pressure (Cooling)	kPa		1,608			
Surface Air Velocity	m/s		2.18	2.79	1.97	2.16
Sound Pressure Level (H/M/L)	dBA		50 / 46 / 42	54 / 52 / 50	58	58
Unit Dimension	Height	mm (in)	572 (23)		885 (35)	
	Width	mm (in)	1,402 (55)		1,540 (61)	
	Depth	mm (in)	605 (24)		850 (33)	
Packing Dimension	Height	mm (in)	762 (30)		1,154 (45)	
	Width	mm (in)	1,605 (63)		1,787 (70)	
	Depth	mm (in)	880 (35)		1,188 (47)	
Unit Weight	kg (lb)		92 (203)	102 (225)	176 (388)	189 (417)
Condensate Drain Pipe Size	mm (in)		19.05 (3/4)			
Pipe Connection	Type		BSP FEMALE THREAD ADAPTOR			
	Size	mm (in)	31.75 (1 1/4)			
Filter	Type		WASHABLE SARANET FILTER		VILEDON R29	
	Quantity	pcs	2		3	
Casing	Colour		IVORY WHITE			

Notes:

1. Nominal cooling capacity are based on the conditions below:

Mode	Cooling
Entering Air Temperature	27°C DB / 19°C WB
Entering Water Temperature	7°C
Leaving Water Temperature	12°C

2. Sound measurement position is 1m in front and center of the unit.

3. All specifications are subjected to change by the manufacturer without prior notice.

Specifications

ADB 200FW - ADB 300FW (Ducted Blower)

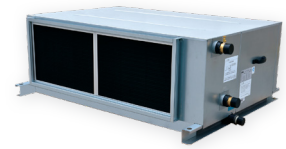

Indoor Model Name			ADB 200FW	ADB 240FW	ADB 300FW
Nominal Cooling Capacity	BTU/h		200,900	239,400	299,800
	KW		58.89	70.17	87.87
Motor Output Power	kW		4	4	5.5
Power Source	V/Ph/Hz		380 ~ 415/3/50		
Control	Air Discharge		HORIZONTAL & NON - CONVERTIBLE		
	Operation		NO CONTROLLER		
Air Flow Rate	High	l/s	2,611	3,083	3,806
		CFM	5,533	6,533	8,064
External Static Pressure With Filter	Pa (in.wg)		250 (1.0)	300 (1.2)	
Nominal Water Flow Rate	USGPM		44.1	52.9	66.3
	Liters/min		166.8	200.4	250.8
Head Loss (Cooling)	kPa		24.66	28.81	39.39
Maximum Working Pressure (Cooling)	kPa		1,600		
Surface Air Velocity	m/s		2.75	2.76	2.75
Sound Pressure Level	dBA		65.3	65.3	67
Unit Dimension	Height	mm (in)	620 (24)	715 (28)	740 (29)
	Width	mm (in)	2,180 (86)	2,270 (89)	2,490 (98)
	Depth	mm (in)	900 (35)	990 (39)	
Packing Dimension	Height	mm (in)	857 (34)	883 (35)	908 (36)
	Width	mm (in)	2,460 (97)	2,680 (106)	2,900 (114)
	Depth	mm (in)	1,220 (48)		
Unit Weight	kg (lb)		234 (516)	269 (593)	306 (675)
Condensate Drain Pipe Size	mm (in)		31.75 (1 1/4)		
Pipe Connection	Type		BSP FEMALE THREAD ADAPTOR		
	Size	mm (in)	63.5 (2 1/2)		
Filter	Type		G3		
	Quantity	pcs	1		
Casing	Colour		WITHOUT PAINT		

Notes:

1. Nominal cooling capacity are based on the conditions below:

Mode	Cooling
Entering Air Temperature	27°C DB / 19°C WB
Entering Water Temperature	7°C
Leaving Water Temperature	12°C

- The external static pressure is inclusive of a flat Grade 3 filter contribute a pressure drop of 88 Pa.
- The unit weight stipulated are net weight, operating weight will increase approximately 20%.
- The sound pressure level value is estimated and the position is 1 m below and after the supply duct.
- All specifications are subjected to change by the manufacturer without prior notice.



ACSON MALAYSIA SALES & SERVICE SDN.BHD.

a member of DAIKIN group

Business Registration NO.198401017130 (129688-D)

Lot 4, Lorong 19/1A, Seksyen 19, 46300 Petaling Jaya,
Selangor Darul Ehsan, MALAYSIA.

Tel : +603 7964 8200 Sales Fax : +603 7956 9909

Service Fax : +603 7956 9907 Acson Careline : 1300 22 3344

Penang	: +604-5377 176	Pahang	: +609-5178 696
Perak	: +605-3129 828	Kelantan	: +609-7405 233
Melaka	: +606-2926 196	Sarawak	: +6082-344 128
Johor	: +607-3551 599	Sabah	: +6088-420 205

www.acson.com.my

Authorized Dealer :

Products manufactured in an ISO certified facility.
This document contains the most current product information as of this printing.
For the most up-to-date product information, please logon to www.acson.com.my